

WEEN HIDE 110 | ERRE



**Il nuovo programma per sistemi R40 con
cerniere a scomparsa ed apertura a 110 gradi**

The new program with 110° concealed hinges for R40 Systems

La soluzione invisibile per ogni tipo di apertura

The invisible solution for all opening types





01

WEEN HIDE 110 ERRE
La prima ed unica soluzione invisibile per SISTEMI R40 con apertura a 110°

The first and only solution with 110° concealed hinges
pag. 4

02

Perché scegliere WEEN HIDE 110 ERRE
Why choosing WEEN HIDE 110 ERRE

pag. 5

03

WEEN HIDE 110 ERRE
ANTA RIBALTA / TILT & TURN

pag. 6

04

WEEN HIDE 110 ERRE
BATTENTE / CASEMENT -
DOPPIA ANTA/ DOUBLE SASH

pag. 19

05

Articoli complementari
Complementary Articles

pag. 26

06

Configurazioni Anta Ribalta
Tilt & Turn Configuration

pag. 32

07

Configurazioni Battente
Casement configuration

pag. 36

07

Configurazioni Vasistas
Vasistas configuration

pag. 36

WEEN HIDE 110 ERRE

La prima ed unica soluzione invisibile per SISTEMI R40 con apertura a 110°

The first and only solution with 110° concealed hinges



WEEN HIDE 110 ERRE

La prima ed unica soluzione invisibile per SISTEMI R40 con apertura a 110°

WEEN HIDE 110 ERRE è una soluzione unica in grado di soddisfare importanti requisiti di portata, estetica, funzionalità e durabilità.

WEEN HIDE 110 ERRE è una soluzione semplice, modulare e green, ideata da Master per sistemi anta ribalta. Ha un design essenziale dotato di cerniere a scomparsa (apertura 110°) ed è adattabile sia per sistemi a battente che per le chiusure ad anta ribalta.

WEEN HIDE 110 ERRE può essere installato in abbinamento a WiCloud (il primo sistema di motorizzazione invisibile per finestre) consentendo di creare valore su progetti architettonici di pregio, dove tutti gli elementi risultano nascosti e la movimentazione è completamente automatica.

WEEN HIDE 110 ERRE è progettato per portate fino a 110 kg con apertura a 110° ed è possibile arrivare fino a 140 kg con l'apposito sostegno. Facile e veloce da assemblare grazie al sistema di montaggio rapido e alla cerniera che permette la regolazione 3D.

WEEN HIDE 110 ERRE

The first and only solution with 110° concealed hinges

WEEN HIDE 110 ERRE the unique solution that meets the requirements of maximum load, design, functionality, durability.

WEEN HIDE 110 ERRE is the solution for tilt & turn system easy modular and green, with a clear modern design with concealed hinges (110° opening angle) and it is usable for casement and tilt and turn systems.

WEEN HIDE 110 ERRE can be installed in combination with WiCloud (the first concealed system for window automation) to create value to architectural design projects, where all elements are hidden and handling is fully automatic.

WEEN HIDE 110 ERRE is suitable for leaf weights of up to 110 kg 110° opening and is easily upgradable for leaf weights up to 140 kg with the special sash support. It's easy to use thanks the fast assembly system and the hinge for an opening angle of 180° that allows the 3D-adjustment.



Perché scegliere WEEN HIDE 110 ERRE



Why choosing WEEN HIDE 110 ERRE

➤ Soluzione invisibile / Invisible Solution

Le cerniere invisibili e la possibilità di essere utilizzato con le motorizzazioni a scomparsa “WiCloud”, permettono al nuovo sistema di essere completamente invisibile garantendo un design elegante ed essenziale.

This design impact without visible hinge and with the possibility to use in combination with “WiCloud”, the concealed system for window automation, allow the new opening system to be completely invisible ensuring an elegant and minimal design.

➤ Grande versatilità / Great flexibility

Il sistema WEEN HIDE 110 ERRE fa parte del PROGRAMMA WEEN di Master che offre la possibilità di abbinare al kit chiusura i diversi gruppi cerniere (standard o a scomparsa). Il sistema può essere utilizzato con profili a battente per realizzare tutti i tipi di apertura: anta ribalta, apertura interna ed esterna, apertura a vasistas.

The WEEN HIDE 110 ERRE system is part of the Master WEEN PROGRAM which offers the possibility of combining the different hinge units (standard or concealed) with the closing kit. This system can be used for all opening types used with casement profiles: tilt and turn opening, Inside/Outside side opening, bottom hung opening.

➤ Prestazioni / Performance

Il nuovo programma è testato per portate fino a 110 kg con apertura a 110°. E' possibile arrivare fino a 140 kg. La cerniera con angolo di apertura a 110° permette anche la regolazione 3D.

The new program is suitable for leaf weights of up to 110 kg 110° opening. It is easily upgradable for leaf weights up to 140 kg with the special sash support. This unique hinge for an opening angle of 110° also allows for 3D-adjustment.

➤ Semplice da installare / Easy mounting

L'assemblaggio della cerniera superiore con braccio è veloce ed intuitivo, infatti basta agganciare anta e telaio grazie all'apposito sistema a scatto sul profilo ed eseguire il fissaggio con 4 viti autofilettanti. La cerniera inferiore può essere facilmente montata in cantiere o in officina come un comune meccanismo anta ribalta.

The assembly of the upper hinge with arm is fast and intuitive, in fact it is sufficient to hook the leaf and the frame thanks to the special click system on the profile and perform the fixing with 4 self-tapping screws. The lower hinge can be easily mounted on site or in the workshop as a common tilt-and-turn mechanism.

WEEN HIDE 110 ERRE

ANTA RIBALTA / TILT & TURN

03

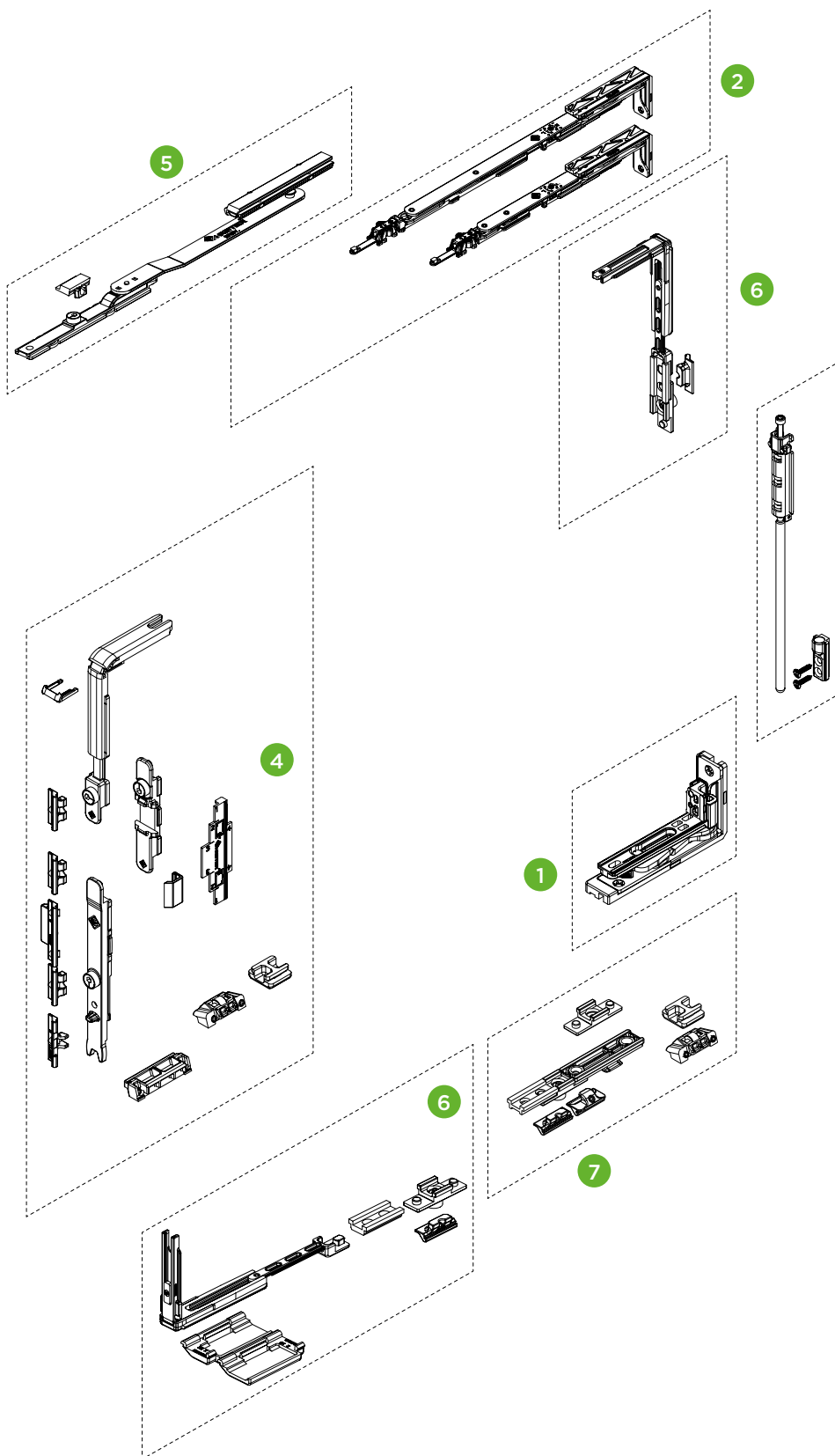

- 1** 3313 S/D
Cerniera a scomparsa inferiore regolabile per A/R
Low concealed hinge for T&T
- 2** 3313.20 S/D | 3313L.20 S/D
Cerniera a scomparsa con braccio corto regolabile per A/R e A/R logica
Concealed Hinge with adjustable short arm for T&T and Logic T&T
3313.21 S/D | 3313L.21 S/D
Cerniera a scomparsa con braccio lungo regolabile per A/R e A/R logica
Concealed Hinge with adjustable long arm for T&T and Logic T&T
- 3** 3310.50
Supporto anta autodimante
Self-positioning sash support per portate >110 <140 Kg
- 4** 3321G.1/2 | 3321LG.1/2
Kit di chiusura Ween Hide
Ween Hide closing kit
- 5** 3521.30 | 3521L.30
Braccio supplementare per anta ribalta
Tilt and turn additional arm
- 6** 3421.31
Kit chiusure verticali e orizzontali
Kit locking points
- 7** 3421.35
Chiusura orizzontale
Extra locking point

WEEN ERRE KIT CHIUSURE



Kit chiusure Ween ERRE | Ween ERRE closing kit | Kit de fermeture Ween ERRE | Kit de cierre Ween ERRE



Rinvio d'angolo, terminali e riscontri in zama.



Corner return, terminals and handles in zamak.



Renvoi d'angle, embout de tringle et gâches en zamak.



Reenvío de ángulo Bloqueo y cerradero de zamak.



ART.	3321G.1				3321LG.1			
Imballo Package Conditionnement Embalaje	5 Kit				5 Kit			
Finiture disponibili Available finishes Finitions disponibles Acabados disponibles	1	2	3	4	1	2	3	4

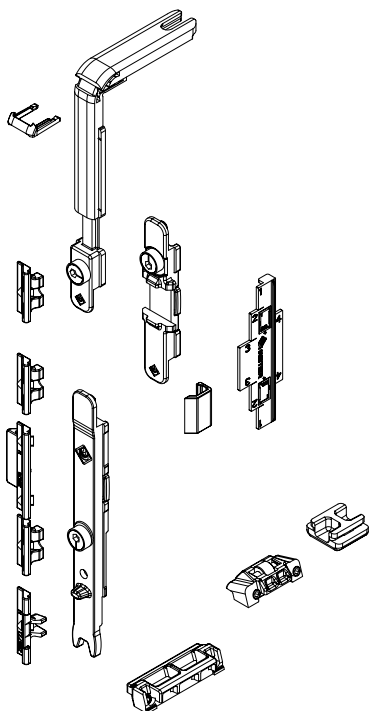

Art. 3321G.1

Kit base standard con antifalsamanovra sulla cremonese
Standard kit with *anti-false manoeuvre on cremone bolt (AFM)*

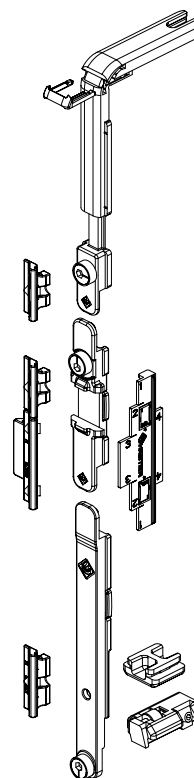
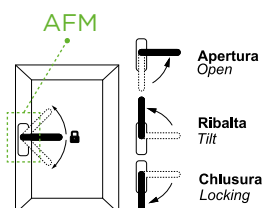

Art. 3321LG.1

Kit base manovra logica con antifalsamanovra sulla cremonese
Logic version with *anti-false manoeuvre on cremone bolt (AFM)*

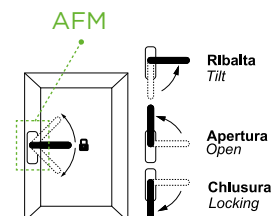

WEEN ERRE KIT CHIUSURE



Kit chiusure Ween ERRE | Ween ERRE closing kit |
Kit de fermeture Ween ERRE | Kit de cierre Ween ERRE



Rinvio d'angolo,
terminali e riscontri
in zama.



Corner return,
terminals and handles
in zamak.



Renvoi d'angle,
embout de
tringle et gâches en
zamak.



Reenvío de
ángulo Bloqueo y
cerradero de zamak.



ART.	3321G.2				3321LG.2			
Imballo Package Conditionnement Embalaje	5 Kit				5 Kit			
Finiture disponibili Available finishes Finitions disponibles Acabados disponibles	1	2	3	4	1	2	3	4

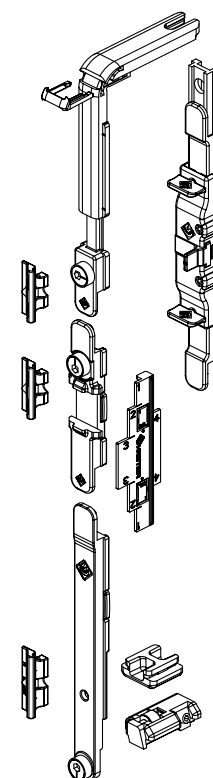
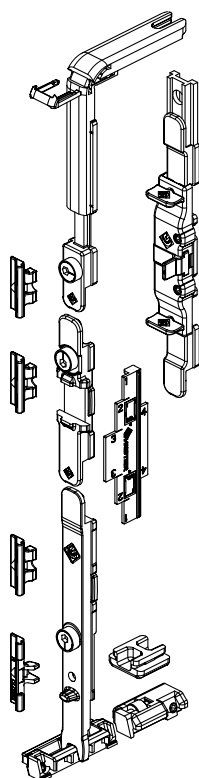

Art. 3321G.2
Kit base standard con
**antifalsamanovra
superiore**
*Standard kit with **upper
anti-false manoeuvre
(AFM)***

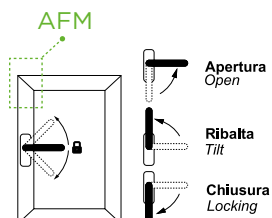

Art. 3321LG.2
Kit base manovra logica
con **antifalsamanovra
superiore**
*Logic version with **upper
anti-false manoeuvre
(AFM)***

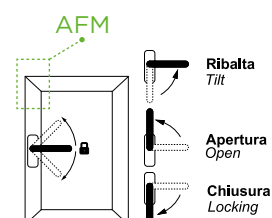

WEEN HIDE 110 ERRE

CERNIERA INFERIORE



Cerniera a scomparsa inferiore regolabile per A/R |
Adjustable Lower Concealed Hinge for T&T |
Paumelle invisible inférieure réglable por O/B | Bisagra Oculta inferior para O/B



Leve in acciaio,
corpo di regolazione
in zama. Portata
massima:
110 Kg - 140 Kg
in abbinamento a
3310.50



Levers in stainless
steel, fixing -set
zamac body.
Maximum load :
110kgs- 140Kgs
combined with
3310.50



Leviers en acier,
corps de réglage
en zamak. Portée:
110 kgs- 140 kgs, à
assortir avec 3310.50



Levas de acero,
cuerpo de regulación
de zamac. Soporta
hasta: 110 kgs- 140
kgs, se combina con
3310.50

ART.	3313 S/D			
Imballo Package Conditionnement Embalaje	5 Pz			
Finiture disponibili Available finishes Finitions disponibles Acabados disponibles	1	2	3	4

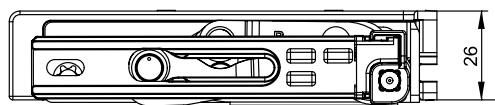
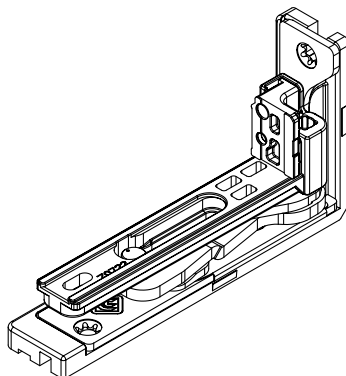
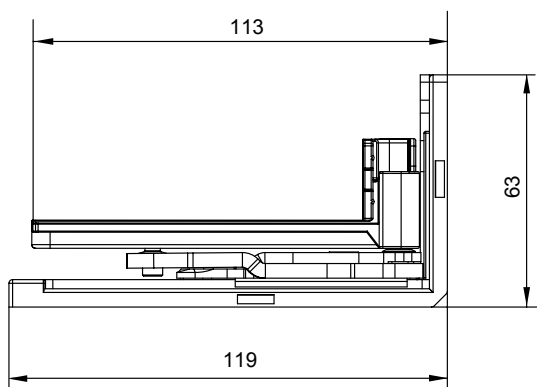
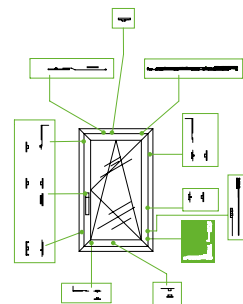

REGOLAZIONI | ADJUSTEMENT

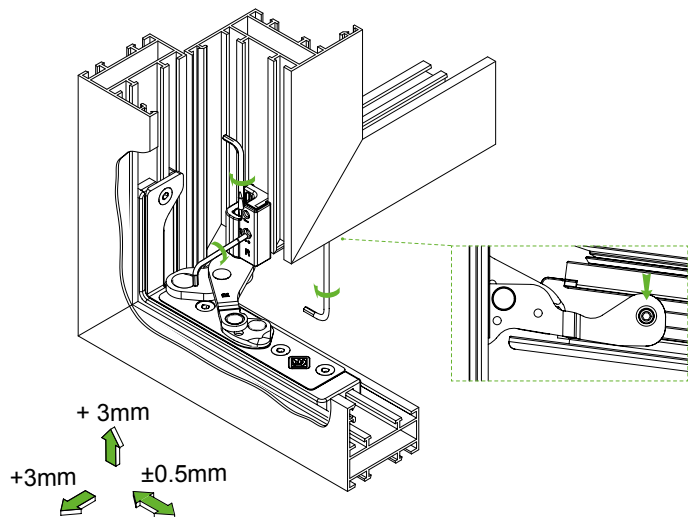

WEEN HIDE 110 ERRE

CERNIERA SUPERIORE



Cerniera a scomparsa con braccio regolabile per A/R e A/R logica |
 Concealed Hinge with adjustable arm for T&T and logic T&T |
 Paumelle invisible avec bras réglable pour O/B et logique |
 Bisagra oculta con compás de regulación para O/B y O/B lógica

Leve in acciaio, corpo di regolazione in zama.
 Portata massima: 110 Kg - 140 Kg in abbinamento a 3310.50

Levers in stainless steel, fixing -set zamak body.
 Maximum load : 110kgs- 140Kgs combined with 3310.50

Leviers en acier, corps de réglage en zamak. Portée: 110 kgs- 140 kgs, à assortir avec 3310.50

Levas de acero, cuerpo de regulación de zamac. Soporta hasta: 110 kgs- 140 kgs, se combina con 3310.50

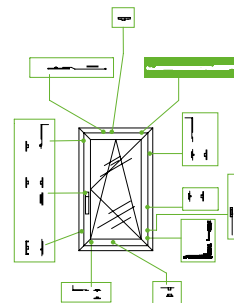

ART.	3313.20S/D 3313L.20S/D					3313.21S/D 3313L.21S/D				
Imballo Package Conditionnement Embalaje	5 Pz				5 Pz					
Finiture disponibili Available finishes Finitions disponibles Acabados disponibles	1	2	3	4	1	2	3	4		

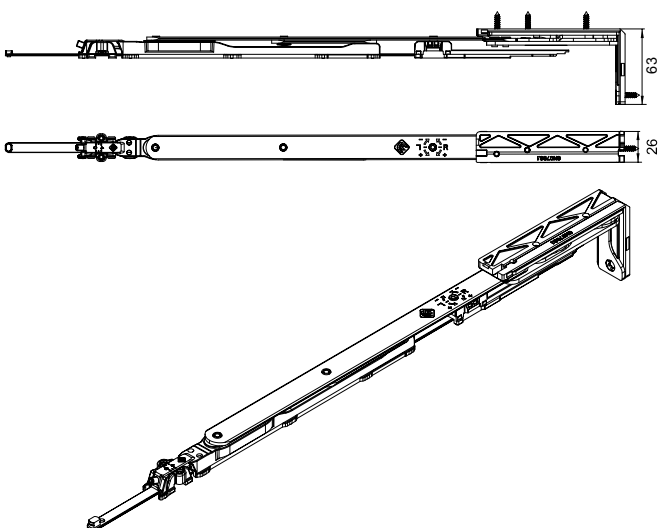

REGOLAZIONI | ADJUSTEMENT

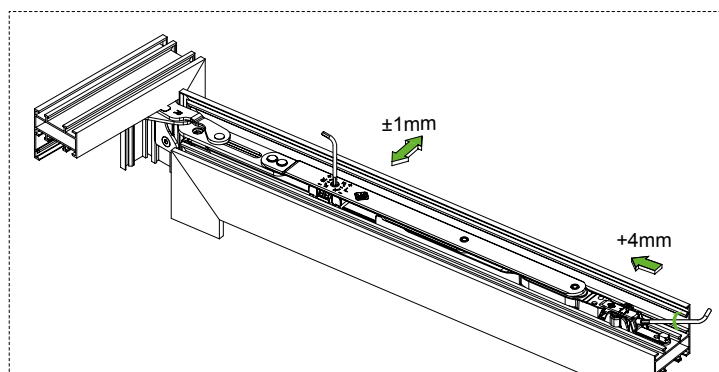

INDICAZIONI DI MONTAGGIO | MOUNTING PHASE

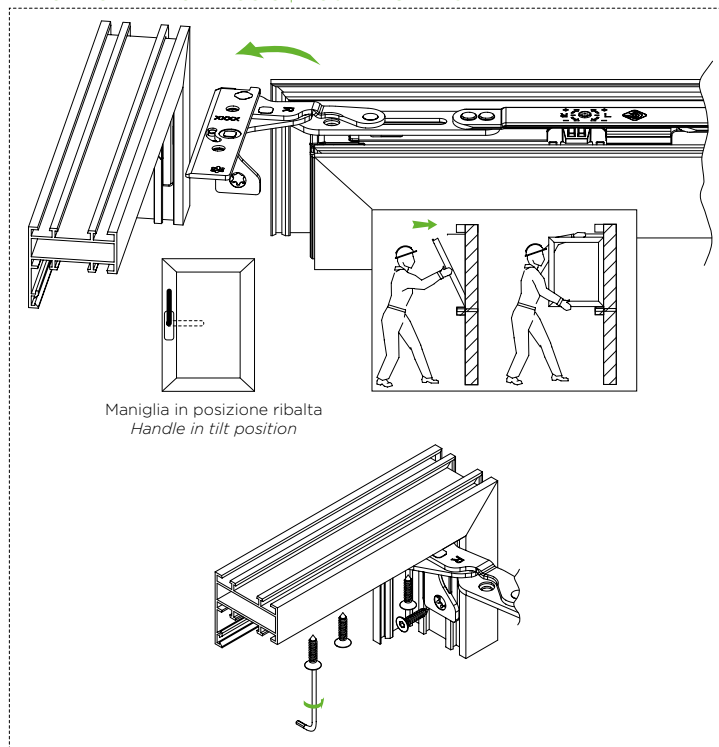

DESCRIZIONE DESCRIPTION	ART.
L anta da 440mm a 570mm* L sash from 440mm to 570mm*	3313.20S/D 3313L.20S/D
L anta da 571mm a 1700mm* L sash from 571mm to 1700mm*	3313.21S/D 3313L.21S/D

* Braccio con aggancio antieffrazione
 * Arm with anti-burglar connection

WEEN HIDE

SUPPORTO ANTA



Supporto anta autodimante | Self-positioninig -sash support |
Support auto positionnant | Soporte con auto colocación



Asta in acciaio,
supporto in zama.
Portata massima:
Ween Hide CE -
150 Kg (Hide 110)
170 kg (Hide 180)
Ween Hide ERRE -
140 Kg (Hide 110)



Stainless steel rod,
zamac support.
Load:
Ween Hide CE -
150 Kg (Hide 110)
170 kg (Hide 180)
Ween Hide ERRE -
140 Kg (Hide 110)



Tringle en acier,
support en zamac.
Portée:
Ween Hide CE -
150 Kg (Hide 110)
170 kg (Hide 180)
Ween Hide ERRE -
140 Kg (Hide 110)



Pletina en acero,
soporte en zamac.
Soporta hasta:
Ween Hide CE -
150 Kg (Hide 110)
170 kg (Hide 180)
Ween Hide ERRE -
140 Kg (Hide 110)



ART.	3310.50			
Imballo Package Conditionnement Embalaje	5 Pz			
Finiture disponibili Available finishes Finitions disponibles Acabados disponibles	1	2	3	4

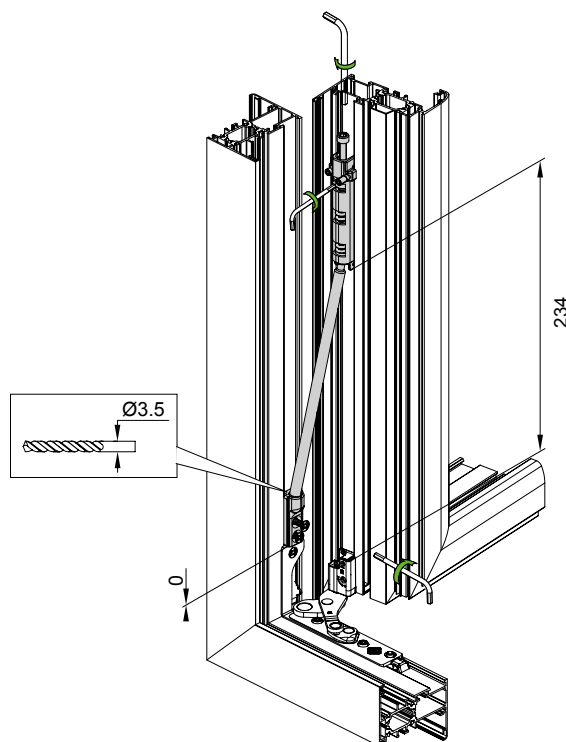
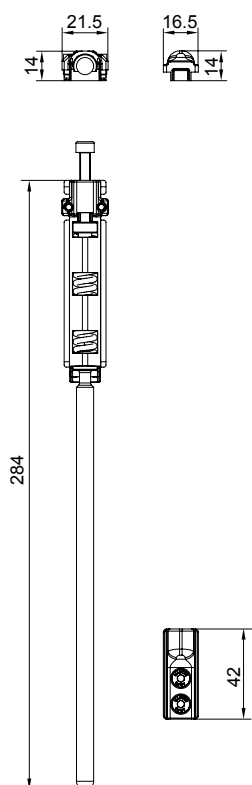
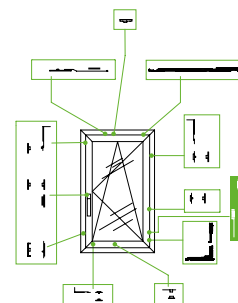

WEEN

BRACCIO SUPPLEMENTARE PER ANTA RIBALTA ERRE

BREVETTATO
PATENTED

1D



2,5

3

Ø8

Braccio supplementare per anta ribalta | Tilt and turn additional arm
 Bras supplémentaire oscillo-battant | Compás suplementario oscilobatiante



Leve, viti e grani in acciaio inox, corpo in zama.



Levers, screw and setscrews in stainless steel, zamak body.



Leviers, vis et grains en acier inox, corps en zamak.



Levas, tornillos y prisioneros de acero inox, cuerpo de zamak.



ART.	3521.30				3521L.30			
Imballo Package Conditionnement Embalaje	5 Pz				5 Pz			
Finiture disponibili Available finishes Finitions disponibles Acabados disponibles	1	2	3	4	1	2	3	4

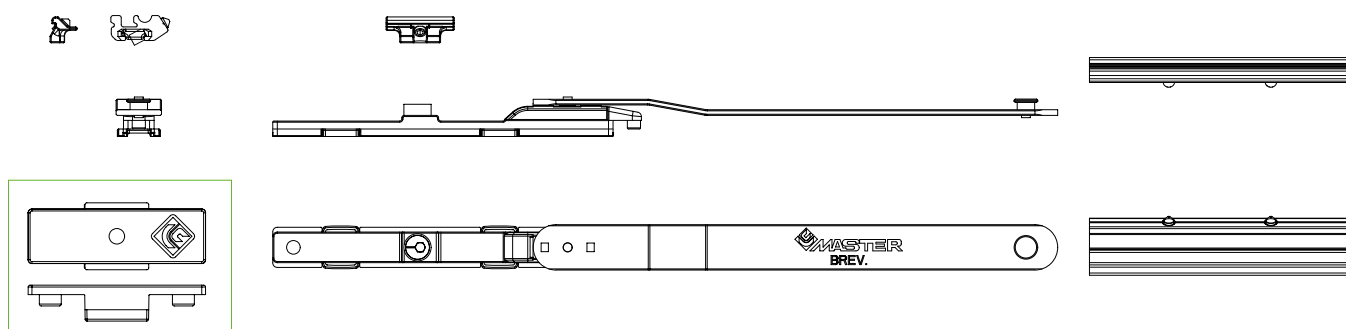
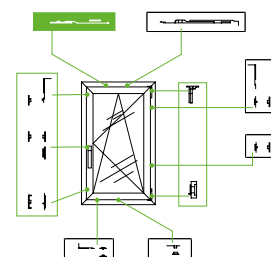

In aggiunta nella versione LOGICA
 Additional in LOGIC version

ANTA RIBALTA TILT AND TURN		
	DESCRIZIONE DESCRIPTION	ART.
WEEN	L anta da 1200mm a 1700mm L sash from 1200mm to 1700mm	3521.30

LOGICA TILT BEFORE TURN		
	DESCRIZIONE DESCRIPTION	ART.
WEEN	L anta da 1200mm a 1700mm L sash from 1200mm to 1700mm	3521L.30

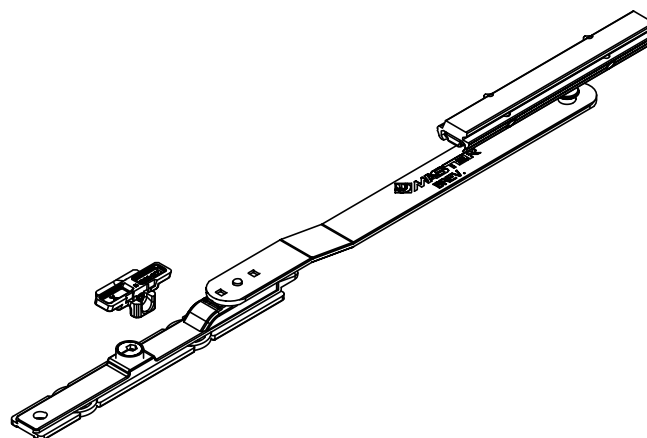

WEEN

CHIUSURE SUPPLEMENTARI ERRE



Kit chiusure verticali e orizzontali | Kit locking points
 Kit points de fermeture | Kit puntos de cierre



Riscontri e punti di chiusura in zama, viti e grani in acciaio inox.



Counterplates and locking points in zamak, screw and setscrews in stainless steel.



Gâches et points de fermeture en zamak vis et grains en acier inox.



Cerraderos y puntos de cierre de zamak, tornillos y prisioneros de acero inox.



ART.	3421.31				3421.32			
Imballo Package Conditionnement Embalaje	10 Kit				50 Kit			
Finiture disponibili Available finishes Finitions disponibles Acabados disponibles	1	2	3	4	1	2	3	4

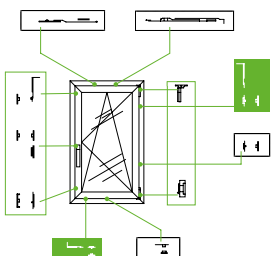

Art. 3421.31

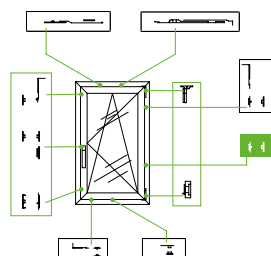

Art. 3421.32

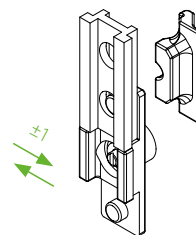
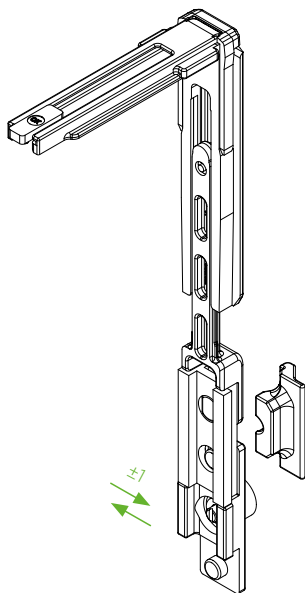

DESCRIZIONE DESCRIPTION	ART.
H anta > 1400mm L anta > 1200mm H sash > 1400mm L sash > 1200mm	3421.31

DESCRIZIONE DESCRIPTION	ART.
H anta > 2200mm L anta > 1200mm H sash > 2200mm L sash > 1200mm	3421.32

WEEN

CHIUSURA ORIZZONTALE INFERIORE ERRE



Chiusura orizzontale per Ween | Extra locking point for Ween | Point de fermeture supplémentaire pour Ween | Punto de cierre extra para Ween



Riscontri e punti di chiusura in zama, viti e grani in acciaio inox, sostegno in nylon, rullino in ottone.



Counterplates and locking points in zamak, screw and setscrews in stainless steel, nylon support and brass roll.



Gâches et points de fermeture en zamak, vis et grains en acier inox, support en nylon et rouleau en laiton.



Cerraderos y puntos de cierre de zamac, tornillos y prisioneros de acero inox, soporte en nylon y rollo en latón.



ART.	3421.35			
Imballo Package Conditionnement Embalaje	10 Kit			
Finiture disponibili Available finishes Finitions disponibles Acabados disponibles	1	2	3	4

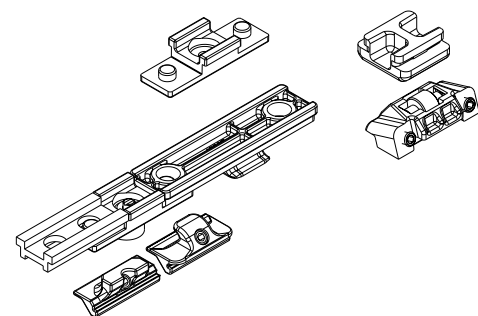
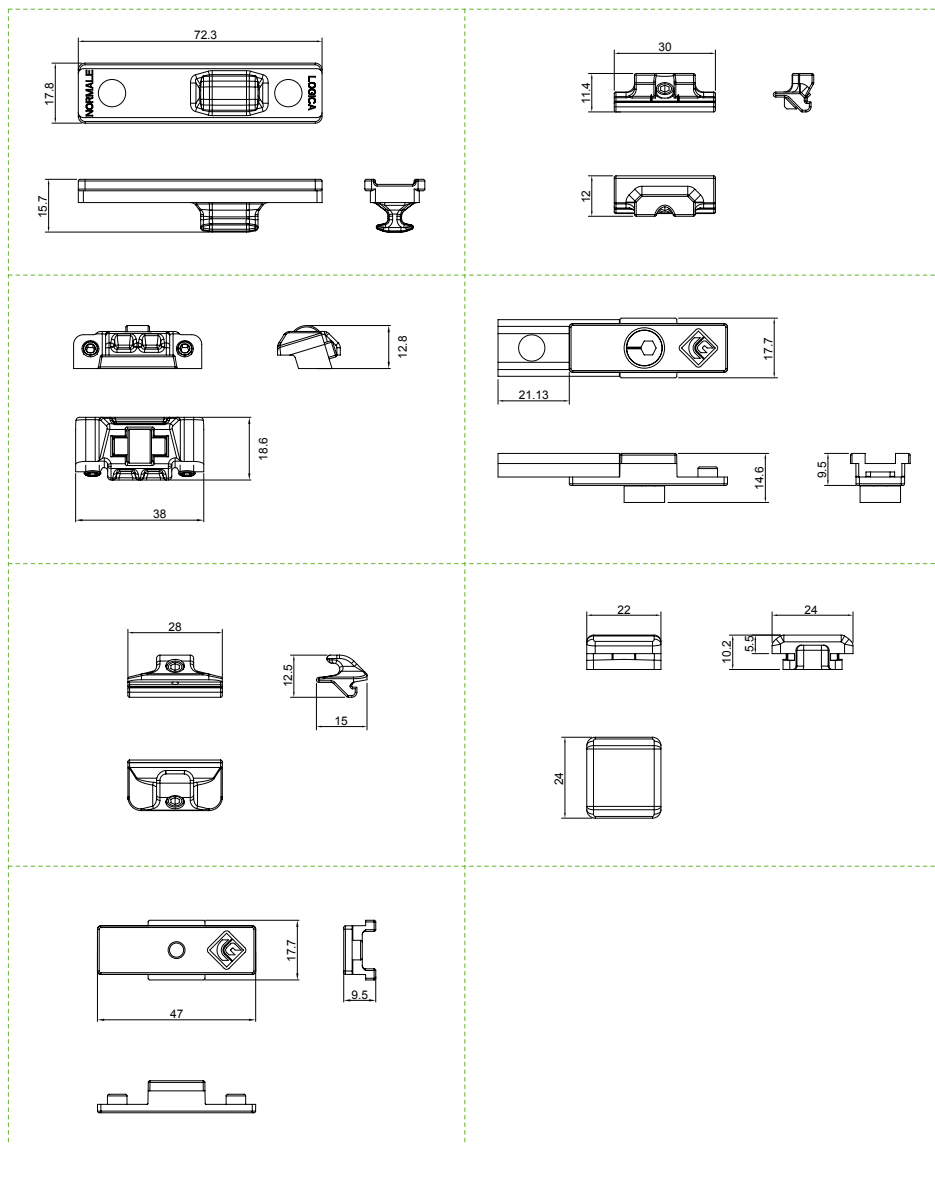
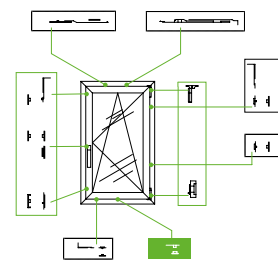

WEEN

MICROVENTILAZIONE ERRE



Microventilazione | Microventilation | Dispositif de micro-ventilation |
Dispositivo de microventilación



Riscontri in zama, viti e grani in acciaio inox.



Counterplates in zamak, screw and setscrews in stainless steel.



Gâches en zamak vis et grains en acier inox.



Cerraderos de zamak, tornillos y prisioneros de acero inox.



ART.	3421.39			
Imballo Package Conditionnement Embalaje	50 Pz			
Finiture disponibili Available finishes Finitions disponibles Acabados disponibles	1	2	3	4

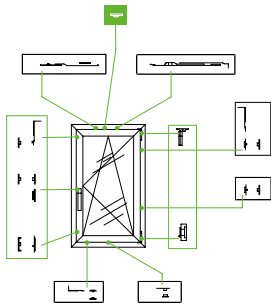

Art. 3421.39

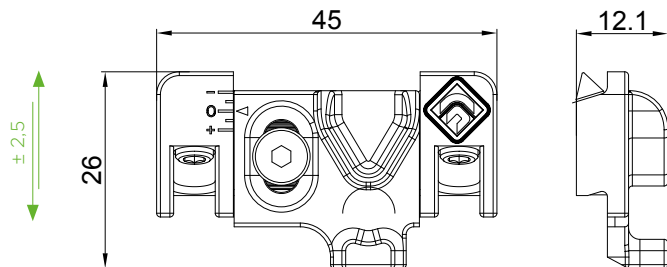

WEEN

PUNTI DI CHIUSURA ANTIEFFRAZIONE



Punti di chiusura antieffrazione | Burglary-resistant locking points |
Points de fermeture antieffraction | Puntos de cierre anti-efracción



Punti di chiusura con perno a funghetto, blocchetti di copertura aggancio astina, blocchetto anti-sollevamento verticale, blocchetto anti-sollevamento orizzontale, braccio anti effrazione in acciaio inox e zama.



Closing point with "T" pin and antilift-off hook, covering elements for clasping rod, antilift-off vertical block, antilift-off horizontal block, opposite clasping arms in stainless steel and zamak.



Points de fermeture avec pivot champignon et gâche anti levage, blocs de couverture accrochage tringle, bloc anti-levage vertical, bloc anti-levage horizontal, bras avec accrochage inverse en acier inox et zamak.



Puntos de cierre con pernio en "T", bloque de cobertura para agarre de pletina, bloqueo anti elevación vertical y horizontal, compás anti- efracción en acero inox y zamac.



ART.	4247.8 4247.6 4247.16 4247.15 4215				3421A.52 3421A.53			
Imballo Package Conditionnement Embalaje	50 Pz.				5 Pz.			
Finiture disponibili Available finishes Finitions disponibles Acabados disponibles	1	2	3	4	1	2	3	4

Art. 4247.6 | 4247.8
Lavorazioni astine
Rods machining

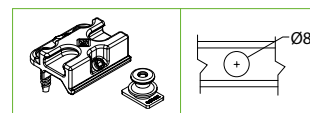

Art. 4247.6

Punto di chiusura antieffrazione con base in zama
Anti-burglar locking-point with zamak plate

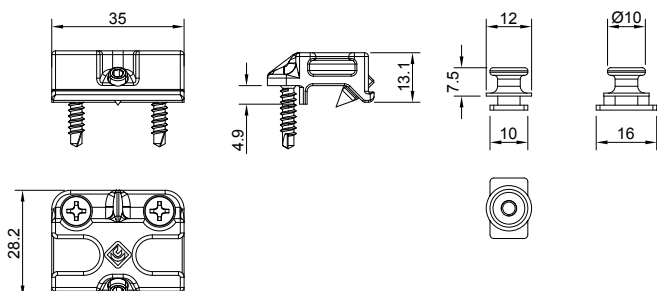

Art. 4247.8

Punto di chiusura antieffrazione con base inox
Anti-burglar locking-point with stainless steel plate

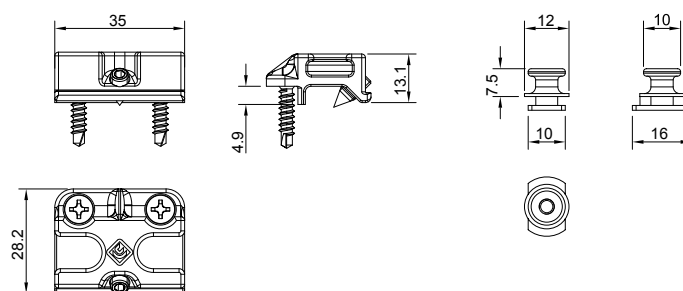

Art. 4247.15

Sistema di sicurezza per connessione astina
Security system connecting rod

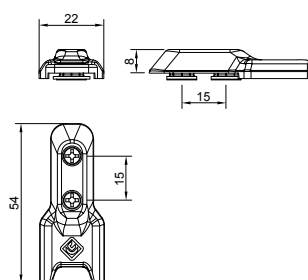

Art. 4247.16

Sistema anti-sollevamento orizzontale
Antilifting horizontal system

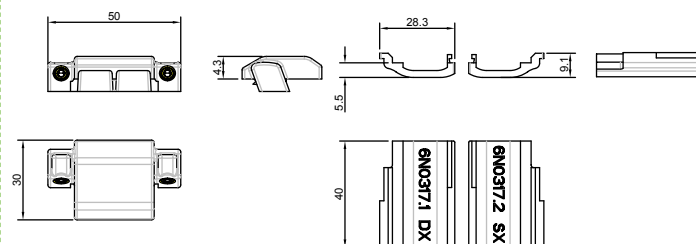

Art. 4215

Sistema anti-sollevamento verticale
Antilifting vertical system

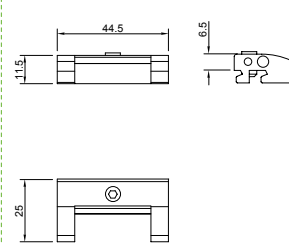

Art. 3421A.52

Punto di chiusura antieffrazione con base in zama
Anti-burglar locking-point with zamak plat

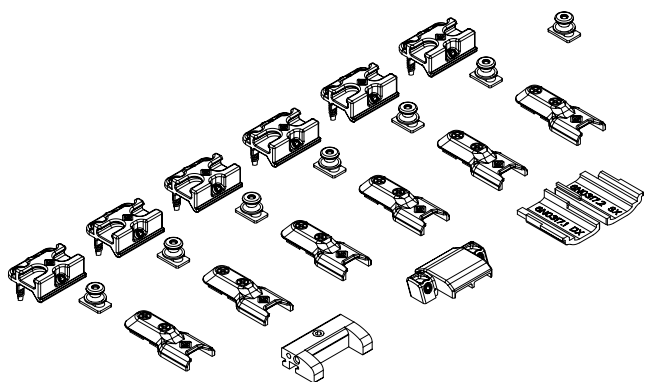

Art. 3421A.53

Punto di chiusura antieffrazione con base inox
Anti-burglar locking-point with stainless steel plate

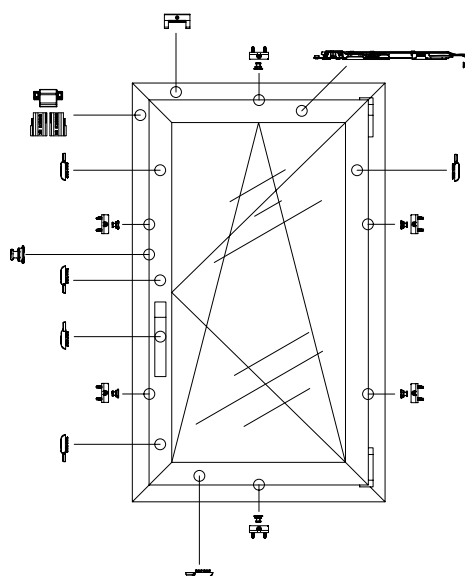
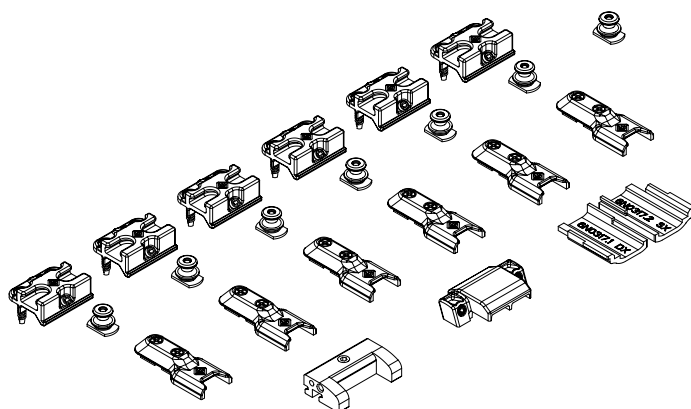

CLASSE RC 2

PROVE ANTIEFFRAZIONE AI
 SENSI DELLE: EN 1627:2011 - EN
 1628: 2011 - EN 1629-1630:2011
 Dimensioni del campione:
 L1230 X H1480 mm

CLASS RC 2

BURGLARY TESTS UNDER THE:
 EN 1627:2011 - EN 1628: 2011 -
 EN 1629-1630:2011
 Sample size: L1230 X H1480 mm

3421A.52 3421A.53	x 6	
	x 6	
	x 1	
	x 1	
	x 1	

Compatibile con sistemi AR Ween
Compatible with AR Ween systems

DIAGRAMMI DI CARICO

LOAD CHART

TABELLE DI CARICO PER CONFIGURAZIONI MONOANTA
LOAD CHARTS FOR ONE SASH CONFIGURATIONS

110 kg

spessore vetro max | maximum thickness of the glass - s [mm]

2700	37	33	27	23	20	18	16	15	14	13	12	11	10	10
2600	38	34	28	24	21	19	17	15	14	13	12	11	11	10
2500	40	35	29	25	22	20	18	16	15	14	13	12	11	10
2400	42	37	31	26	23	20	18	17	15	14	13	12	11	11
2300	43	38	32	27	24	21	19	17	16	15	14	13	12	11
2200	45	40	33	29	25	22	20	18	17	15	14	13	13	12
2100	48	42	35	30	26	23	21	19	17	16	15	14	13	11
2000	50	44	37	31	28	24	22	20	18	17	16	15	14	12
1900	50	46	39	33	29	26	23	21	19	18	17	15	13	12
1800	50	49	41	35	31	27	24	22	20	19	17	15	14	13
1700	50	50	43	37	32	29	26	24	22	20	17	16	15	14
1600	50	50	46	39	34	31	28	25	23	19	18	17	15	12
1500	50	50	49	42	37	33	29	27	24	20	19	18	14	10
1400	50	50	50	45	39	35	31	29	24	22	20	16	12	11
1300	50	50	50	48	42	38	34	28	25	23	18	14	13	8
1200	50	50	50	50	46	41	33	30	28	17	16	15	9	4
1100	50	50	50	50	50	40	36	33	20	18	17	11	6	N.D.
1000	50	50	50	50	50	44	40	24	22	20	13	7	N.D.	N.D.
900	50	50	50	50	50	49	29	27	16	8	N.D.	N.D.	N.D.	N.D.
800	50	50	50	50	50	37	33	20	11	N.D.	N.D.	N.D.	N.D.	N.D.
700	50	50	50	50	47	42	13	N.D.	N.D.	N.D.	N.D.	N.D.	N.D.	N.D.
600	50	50	50	50	37	19	N.D.	N.D.	N.D.	N.D.	N.D.	N.D.	N.D.	N.D.
550	50	50	50	50	N.D.	N.D.	N.D.	N.D.	N.D.	N.D.	N.D.	N.D.	N.D.	N.D.
H \ L	440	500	600	700	800	900	1000	1100	1200	1300	1400	1500	1600	1700

140 kg *

spessore vetro max | maximum thickness of the glass - s [mm]

2700	47	41	35	30	26	23	21	19	17	16	15	14	13	12
2600	49	43	36	31	27	24	22	20	18	17	15	14	13	13
2500	50	45	37	32	28	25	22	20	19	17	16	15	14	13
2400	50	47	39	33	29	26	23	21	19	18	17	16	15	14
2300	50	49	41	35	30	27	24	22	20	19	17	16	15	14
2200	50	50	42	36	32	28	25	23	21	20	18	17	16	15
2100	50	50	44	38	33	30	27	24	22	21	19	18	17	14
2000	50	50	47	40	35	31	28	25	23	22	20	19	18	15
1900	50	50	49	42	37	33	29	27	25	23	21	20	17	16
1800	50	50	50	44	39	35	31	28	26	24	22	19	18	16
1700	50	50	50	47	41	37	33	30	27	25	21	20	19	17
1600	50	50	50	50	44	39	35	32	29	24	23	21	20	15
1500	50	50	50	50	47	41	37	34	31	26	24	22	18	13
1400	50	50	50	50	50	44	40	36	30	28	26	20	15	14
1300	50	50	50	50	50	48	43	35	32	30	23	17	16	10
1200	50	50	50	50	50	50	42	38	35	27	20	19	12	5
1100	50	50	50	50	50	50	46	42	32	23	22	14	6	N.D.
1000	50	50	50	50	50	50	50	38	28	26	16	7	N.D.	N.D.
900	50	50	50	50	50	50	37	34	21	10	N.D.	N.D.	N.D.	N.D.
800	50	50	50	50	50	47	42	25	11	N.D.	N.D.	N.D.	N.D.	N.D.
700	50	50	50	50	50	50	16	N.D.	N.D.	N.D.	N.D.	N.D.	N.D.	N.D.
600	50	50	50	50	47	19	N.D.	N.D.	N.D.	N.D.	N.D.	N.D.	N.D.	N.D.
550	50	50	50	50	N.D.	N.D.	N.D.	N.D.	N.D.	N.D.	N.D.	N.D.	N.D.	N.D.
H \ L	440	500	600	700	800	900	1000	1100	1200	1300	1400	1500	1600	1700

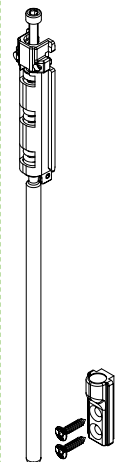

* realizzabile solo con il sostegno 3310.50 | only with sash support 3310.50

WEEN HIDE 110

BATTENTE / CASEMENT - DOPPIA ANTA/ DOUBLE SASH

04

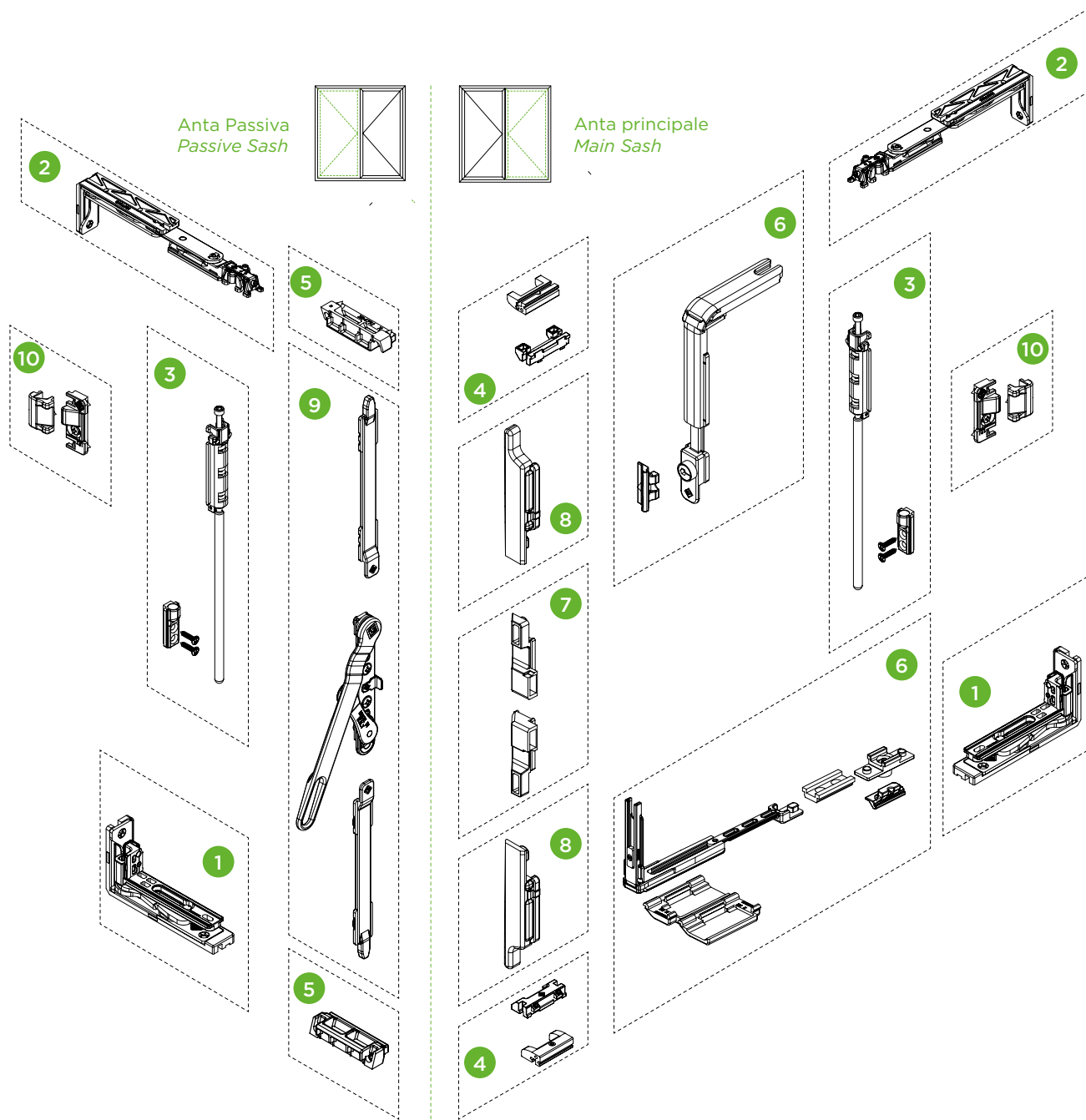

1 3313 S/D
Cerniera a scomparsa inferiore
regolabile per A/R
Low concealed hinge for T&T

2 3313.71 S/D
Cerniera a scomparsa superiore
regolabile per battente
Upper concealed hinge for T&T

3 3310.50
Supporto anta autodimante
Self-positioning sash support

4 4215 | 4217
Riscontro doppio
Upper striker

5 4206
Riscontro doppio
Upper striker

6 1252.11
Rinvio d'angolo completo di
riscontro
*Transmission corner with
counterplate*

7 6402
Blocchetto di collegamento
Connecting block

8 4523
Terminale in zama
Zamak rod - end

9 4516.1
Catenaccio a leva bidirezionale
per anta affiancata
Two-way latch for inactive sash

10 4226.2
Rostro di chiusura supplementare
*Additional intermediate third
closing point*

WEEN HIDE 110 ERRE

CERNIERA INFERIORE



Cerniera a scomparsa inferiore regolabile per A/R |
Adjustable Lower Concealed Hinge for T&T |
Paumelle invisible inférieure réglable por O/B | Bisagra Oculta inferior para O/B



Leve in acciaio,
corpo di regolazione
in zama. Portata
massima:
110 Kg - 140 Kg
in abbinamento a
3310.50



Levers in stainless
steel, fixing -set
zamak body.
Maximum load :
110kgs- 140Kgs
combined with
3310.50



Leviers en acier,
corps de réglage
en zamak. Portée:
110 kgs- 140 kgs, à
assortir avec 3310.50



Levas de acero,
cuerpo de regulación
de zamac. Soporta
hasta: 110 kgs- 140
kgs, se combina con
3310.50

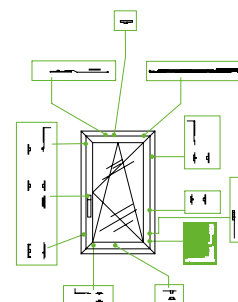

ART.	3313 S/D			
Imballo Package Conditionnement Embalaje	5 Pz			
Finiture disponibili Available finishes Finitions disponibles Acabados disponibles	1	2	3	4

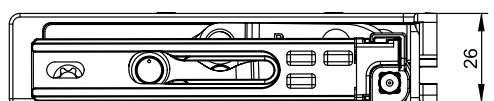
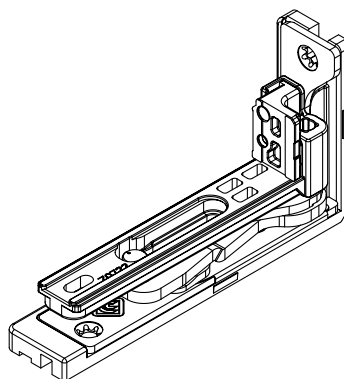
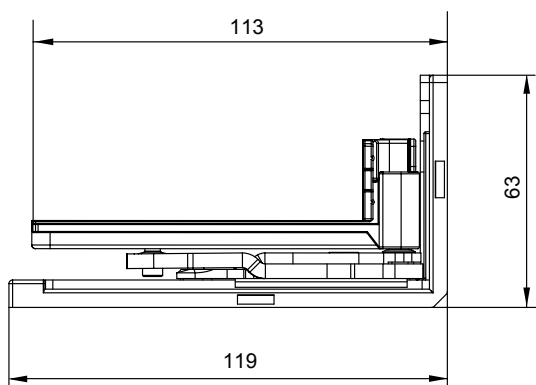

REGOLAZIONI | ADJUSTEMENT

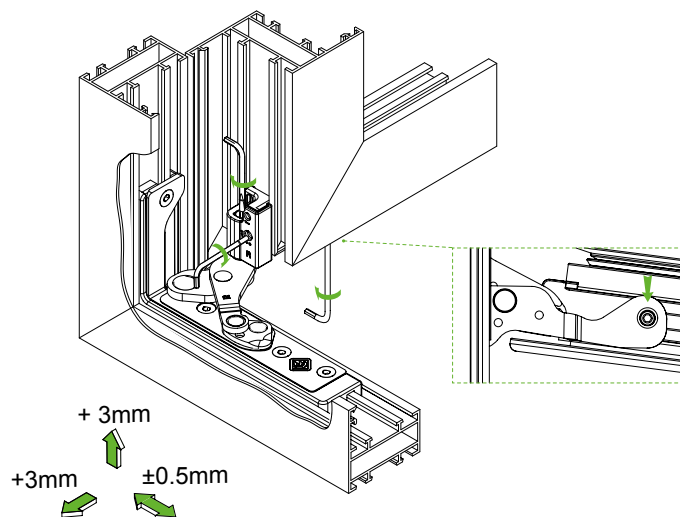

WEEN HIDE 110 ERRE

CERNIERA SUPERIORE (BATTENTE)



Cerniera a scomparsa superiore regolabile per battente | Upper concealed hinge for T&T | Paumelle invisible superieur pour O/B | Bisagra ocultada superior para O/B



Leve in acciaio, corpo di regolazione in zama. Portata massima: 110 Kg - 140 Kg in abbinamento a 3310.50



Levers in stainless steel, fixing-set zamak body. Maximum load : 110kgs- 140Kgs combined with 3310.50



Leviers en acier, corps de réglage en zamak. Portée: 110 kgs- 140 kgs, à assortir avec 3310.50



Levas de acero, cuerpo de regulación de zamac. Soporta hasta: 110 kgs- 140 kgs, se combina con 3310.50



ART.	3313.71 S/D			
Imballo Package Conditionnement Embalaje	5 Pz			
Finiture disponibili Available finishes Finitions disponibles Acabados disponibles	1	2	3	4

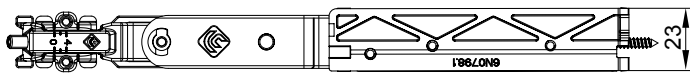
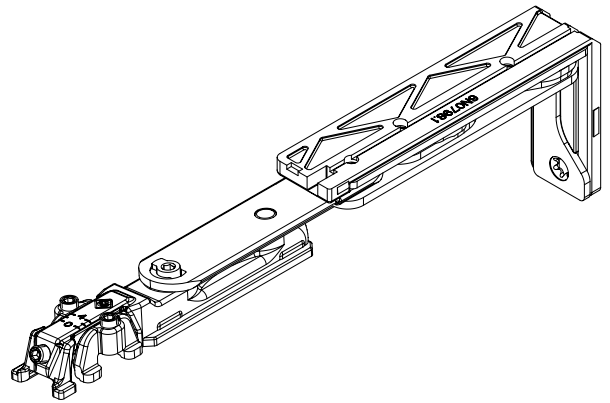
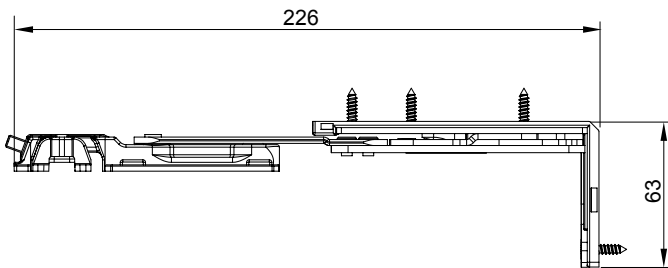
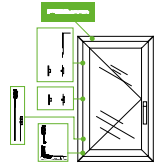

REGOLAZIONI | ADJUSTEMENT

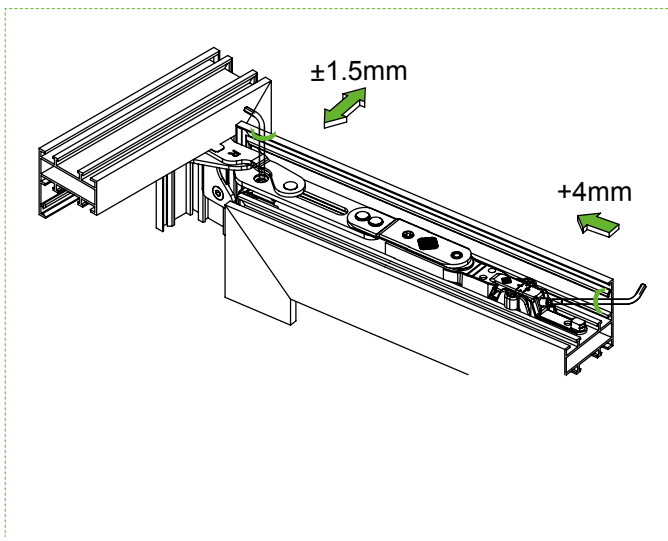

INDICAZIONI DI MONTAGGIO | MOUNTING PHASE

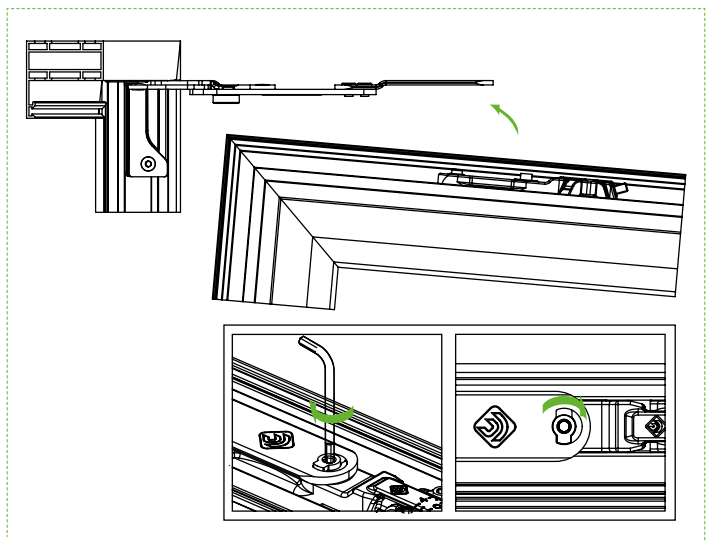

HOOK

Rostro di chiusura supplementare antisollevamento



Rostro di chiusura supplementare | Additional intermediate third closing point | Crochet de fermeture supplementaire | Punto de cierre suplementario



Slitta, riscontro e base riscontro in zamak; vite TSSCCR M4x6 e grano in acciaio inox.



Zamak slider, counterplate and base of the counterplate; TSSCCR M4x6 screw and stainless steel setscrew.



Glissière, gâche et base de la gâche en zamak; vis TSSCCR M4x6 et grain en acier inox.



Resbalón, cerradero y base del cerradero en zamak; tornillo TSSCCR M4x6 y pernio en acero inoxidable.



ART.	4226.2			
Imballo Package Conditionnement Embalaje	40 Kit			
Finiture disponibili Available finishes Finitions disponibles Acabados disponibles	1	2	3	4

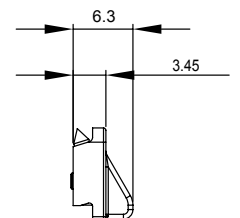
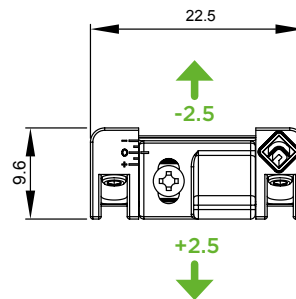
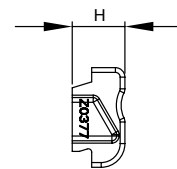
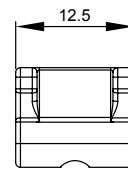
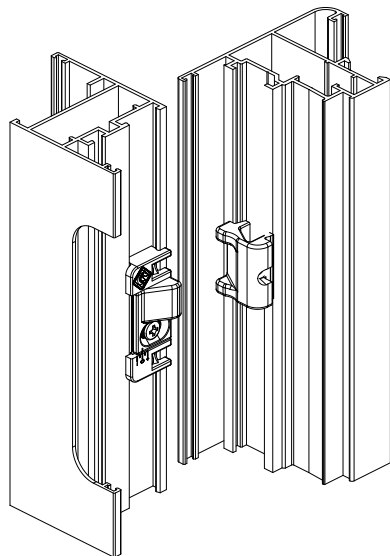
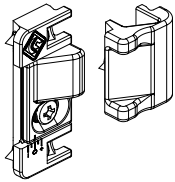

ART.	H
4226.2	6.5

BI-HID

Catenaccio a leva bidirezionale per anta affiancata ERRE 40

Catenaccio a leva bidirezionale per anta affiancata | Two-way latch for inactive sash | Bidirectionnel verrou pour dormant | Pasador bidireccional para hoja pasiva



Movimentazione e puntali in zama; compensatori in delrin; viti e camme in acciaio inox.



Zamak movimentation and push rod; delrin compensators; cams and screws in stainless steel.



Mouvement et gâche terminale en zamak; compensateurs en delrin; cames et vis en acier inox.



Movimiento y puntal de zamac; compensadores en delrin; tornillos y placas en acero inoxidable.



ART.	4516.1				4516.10 4516.15			
Imballo Package Conditionnement Embalaje	10 PZ				20 PZ			
Finiture disponibili Available finishes Finitions disponibles Acabados disponibles	1	2	3	4	1	2	3	4

Art. 4516.10 **1**

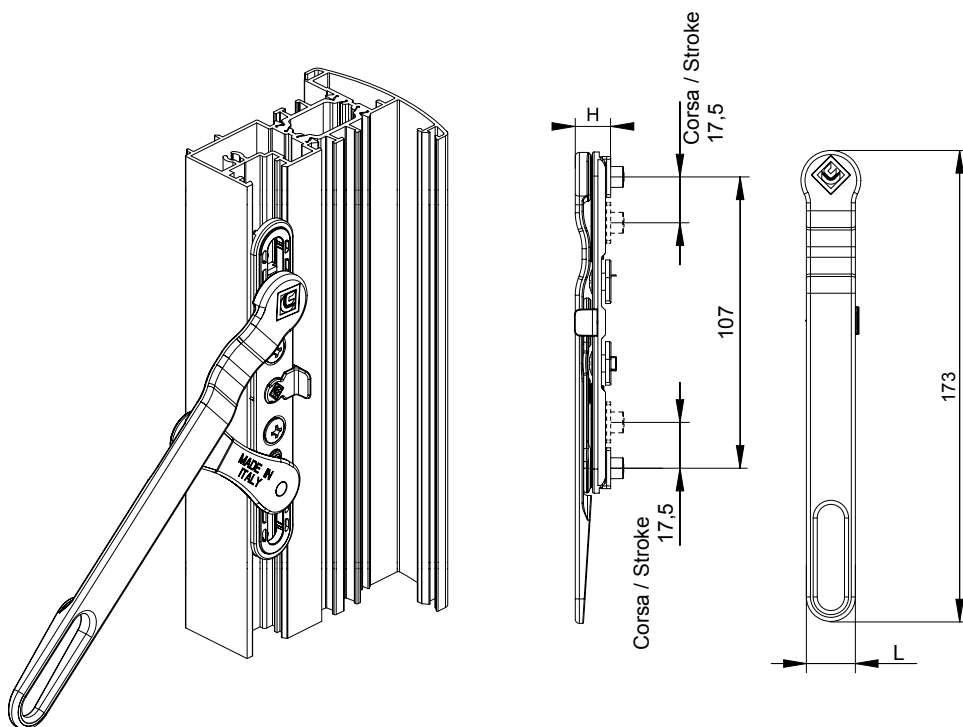

Art. 4516.15 **2**

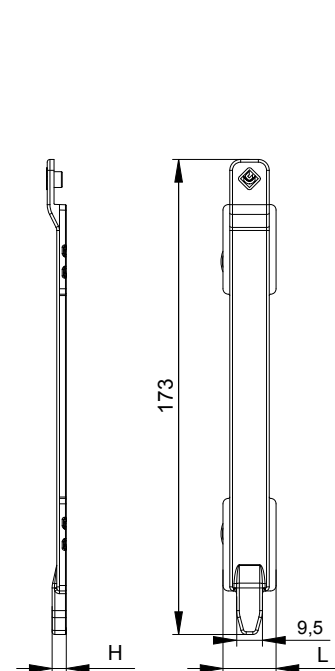

DESCRIZIONE DESCRIPTION	ART	H	L	
Corpo di manovra Slider	4516.10	23	22	1
Terminale superiore ed inferiore Upper and lower rod end	4516.15	6,8	17,5	2
Corpo di manovra + terminale superiore ed inferiore Slider + upper and lower rod end	4516.1	-	-	1 + 2

CONFIGURAZIONI
CONFIGURATIONS

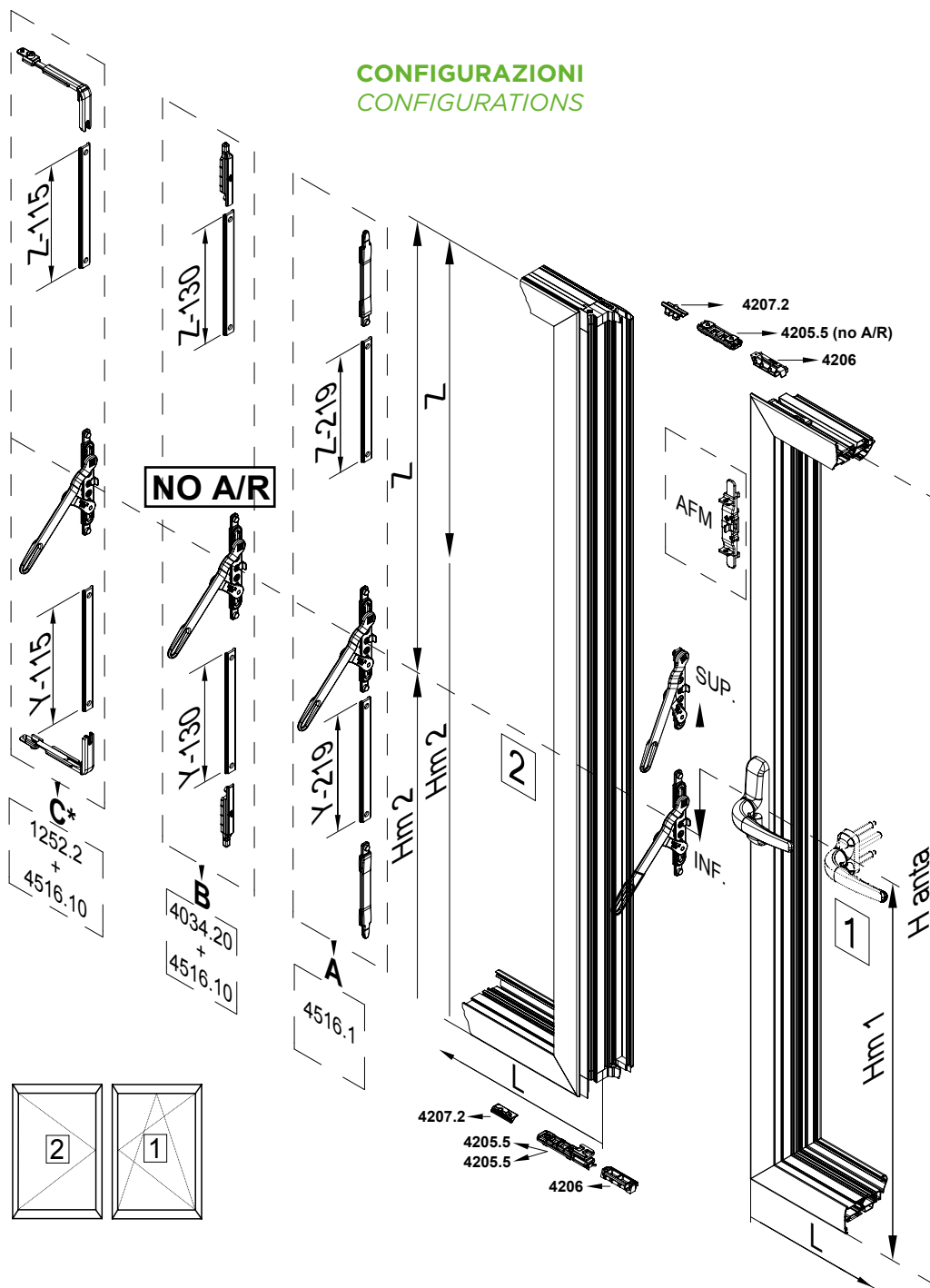

	Inf.				Sup.			
	H anta min.	H anta min.(AFM)	Hm min.	L min.	H anta min.	H anta min.(AFM)	Hm min.	L min.
1	800	900	Hm1	550	800	1100	Hm1	550
			490				300	
2	800	900	Hm2	370	800	1100	Hm2	370
			Hm1-210				Hm1+244	

DIAGRAMMI DI CARICO

LOAD CHART

TABELLE DI CARICO PER CONFIGURAZIONI MONOANTA
LOAD CHARTS FOR ONE SASH CONFIGURATIONS

110 kg

spessore vetro max | maximum thickness of the glass - s [mm]

2700	37	33	27	23	20	18	16	15	14
2600	38	34	28	24	21	19	17	15	14
2500	40	35	29	25	22	20	18	16	15
2400	42	37	31	26	23	20	18	17	15
2300	43	38	32	27	24	21	19	17	16
2200	45	40	33	29	25	22	20	18	17
2100	48	42	35	30	26	23	21	19	17
2000	50	44	37	31	28	24	22	20	18
1900	50	46	39	33	29	26	23	21	19
1800	50	49	41	35	31	27	24	22	20
1700	50	50	43	37	32	29	26	24	22
1600	50	50	46	39	34	31	28	25	23
1500	50	50	49	42	37	33	29	27	24
1400	50	50	50	45	39	35	31	29	24
1300	50	50	50	48	42	38	34	28	25
1200	50	50	50	50	46	41	33	30	28
1100	50	50	50	50	50	40	36	33	20
1000	50	50	50	50	50	44	40	24	22
900	50	50	50	50	50	49	29	27	16
800	50	50	50	50	50	37	33	20	11
700	50	50	50	50	47	42	13	N.D.	N.D.
600	50	50	50	50	37	19	N.D.	N.D.	N.D.
550	50	50	50	50	N.D.	N.D.	N.D.	N.D.	N.D.
H \ L	440	500	600	700	800	900	1000	1100	1200

140 kg *

spessore vetro max | maximum thickness of the glass - s [mm]

2700	47	41	35	30	26	23	21	19	17
2600	49	43	36	31	27	24	22	20	18
2500	50	45	37	32	28	25	22	20	19
2400	50	47	39	33	29	26	23	21	19
2300	50	49	41	35	30	27	24	22	20
2200	50	50	42	36	32	28	25	23	21
2100	50	50	44	38	33	30	27	24	22
2000	50	50	47	40	35	31	28	25	23
1900	50	50	49	42	37	33	29	27	25
1800	50	50	50	44	39	35	31	28	26
1700	50	50	50	47	41	37	33	30	27
1600	50	50	50	50	44	39	35	32	29
1500	50	50	50	50	47	41	37	34	31
1400	50	50	50	50	50	44	40	36	30
1300	50	50	50	50	50	48	43	35	32
1200	50	50	50	50	50	50	42	38	35
1100	50	50	50	50	50	50	46	42	32
1000	50	50	50	50	50	50	50	38	28
900	50	50	50	50	50	50	37	34	21
800	50	50	50	50	50	47	42	25	11
700	50	50	50	50	50	50	16	N.D.	N.D.
600	50	50	50	50	47	19	N.D.	N.D.	N.D.
550	50	50	50	50	N.D.	N.D.	N.D.	N.D.	N.D.
H \ L	440	500	600	700	800	900	1000	1100	1200

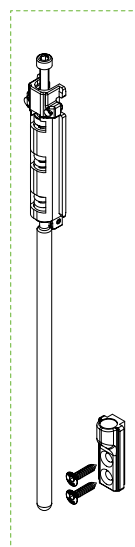

* realizzabile solo con il sostegno 3310.50 | only with sash support 3310.50

WEEN HIDE 110 ERRE

VASISTAS | BOTTOM HUNG

05

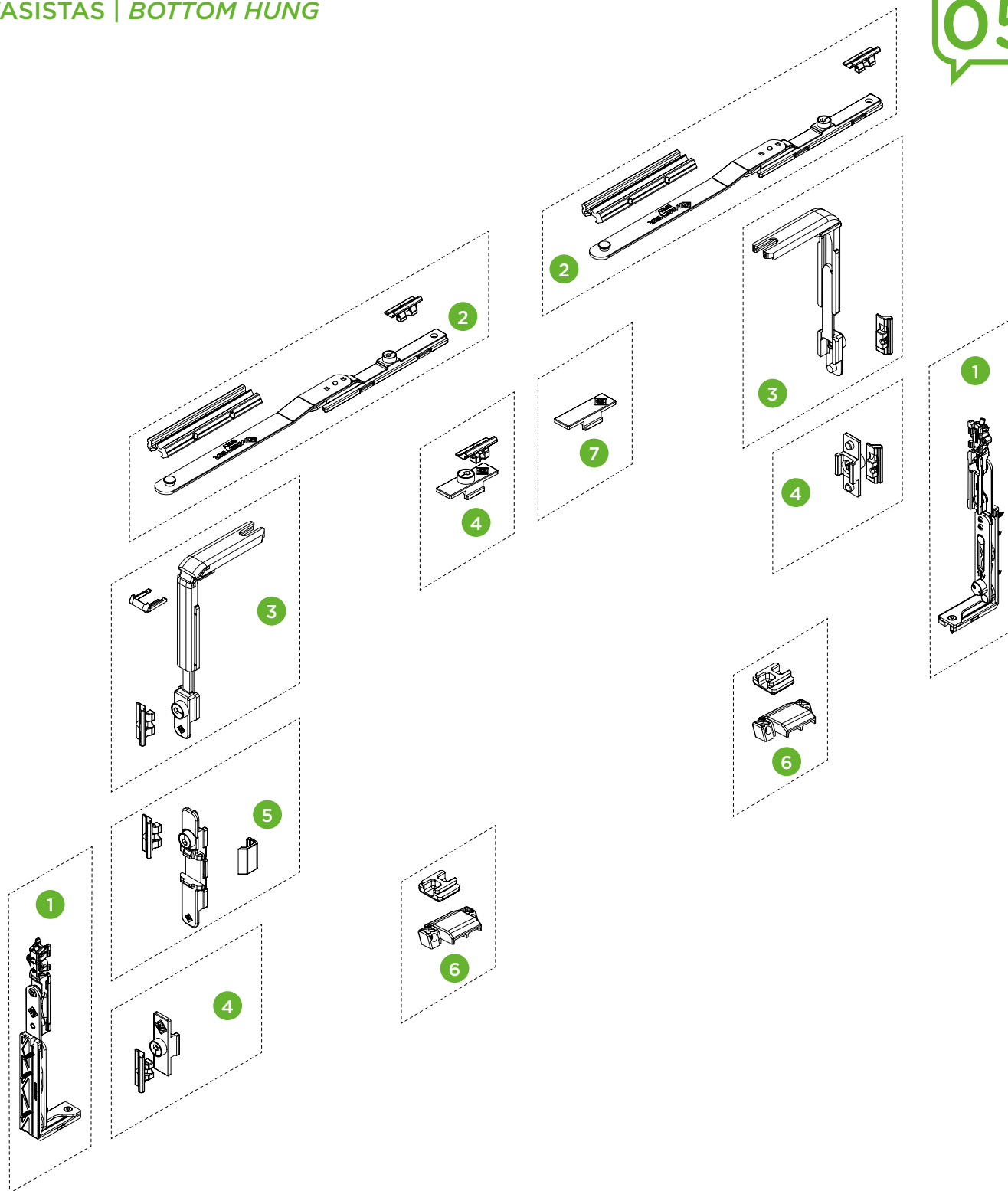

1 3313.70
Cerniere a scomparsa regolabili
per apertura a vasistas
*Concealed adjustable Hinge for
bottom hung*

2 3521.30
Braccio supplementare
Additional arm

3 1252.11
Rinvio d'angolo completo di
riscontro
*Transmission corner with
counterplate*

4 3421.32
Chiusure verticali supplementari
Additional locking points

5 6111.14
Blocchetto di collegamento con
punto di chiusura
*Connecting block with locking
point*

6 3521.33
Kit sostegno anta
Shutter support kit

7 4248.22
Blocchetto
Connecting block

WEEN HIDE 110 ERRE

KIT CERNIERE VASISTAS

BREVETTATO
PATENTED

2D



2,5

3

Cerniere a scomparsa regolabili per apertura a vasistas | Concealed adjustable hinges for transom opening | Paumelle invisible réglable pour vasistas | Bisagra ocultada para basculante



Leve in acciaio, corpo di regolazione in zama.
Portata massima: 100 Kg



Stainless steel levers, fixing-set zamak body. Load : 100 kgs



Levier en acier, corps de regulation en zamac. Portée : 100 kgs.



Levas en acero, cuerpo de regulación de zamac. Soporta hasta : 100 kgs.

ART.	3313.70			
Imballo Package Conditionnement Embalaje	5 Pz			
Finiture disponibili Available finishes Finitions disponibles Acabados disponibles	1	2	3	4

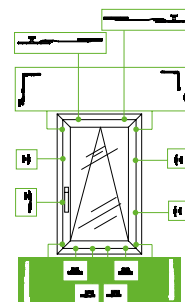
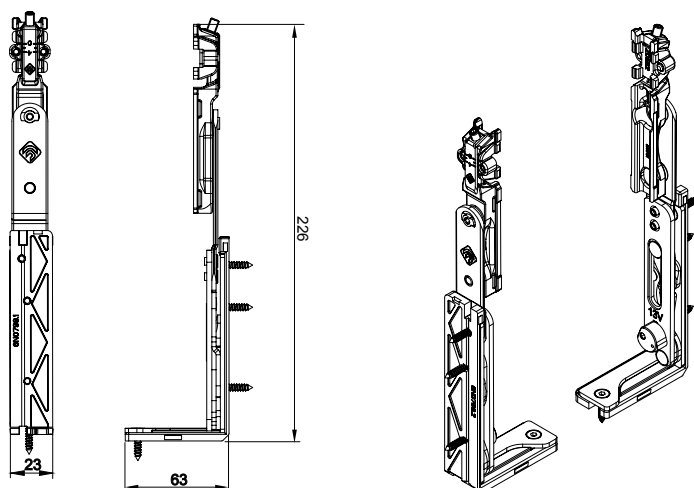

INDICAZIONI DI MONTAGGIO | MOUNTING PHASE

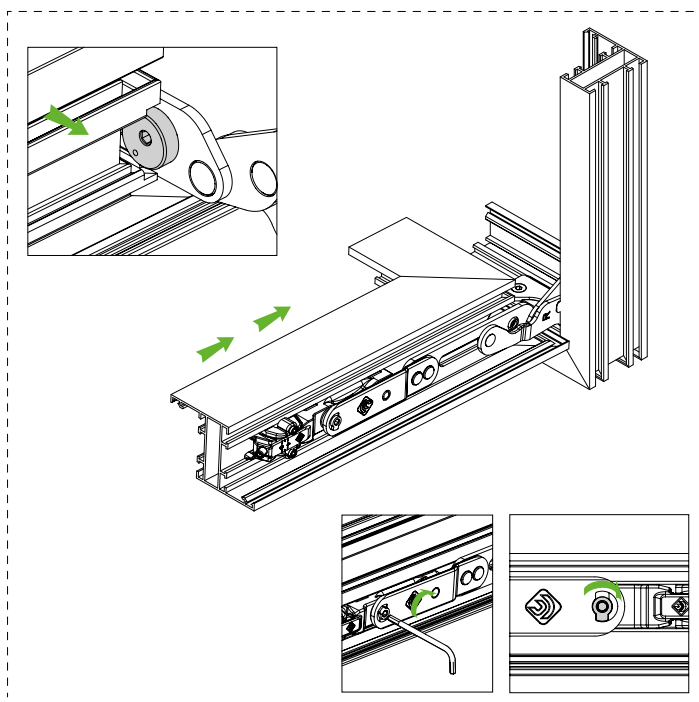

REGOLAZIONI | ADJUSTEMENT

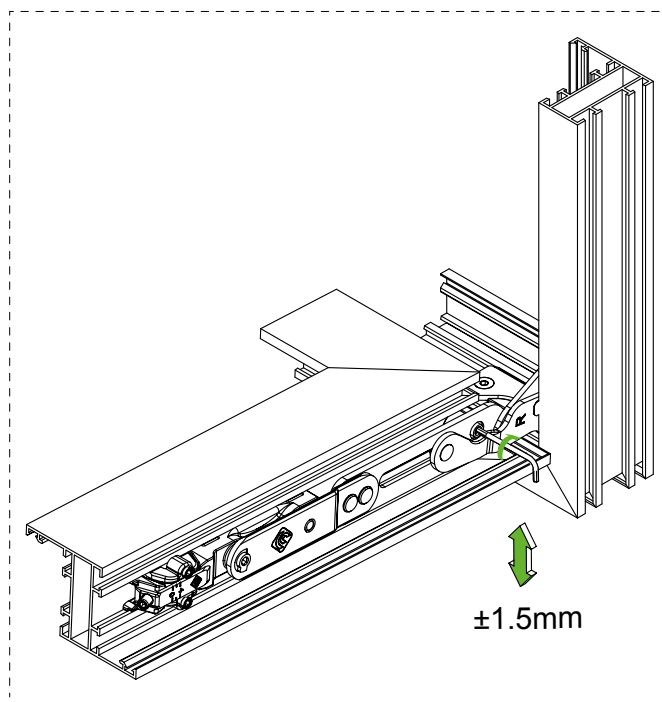

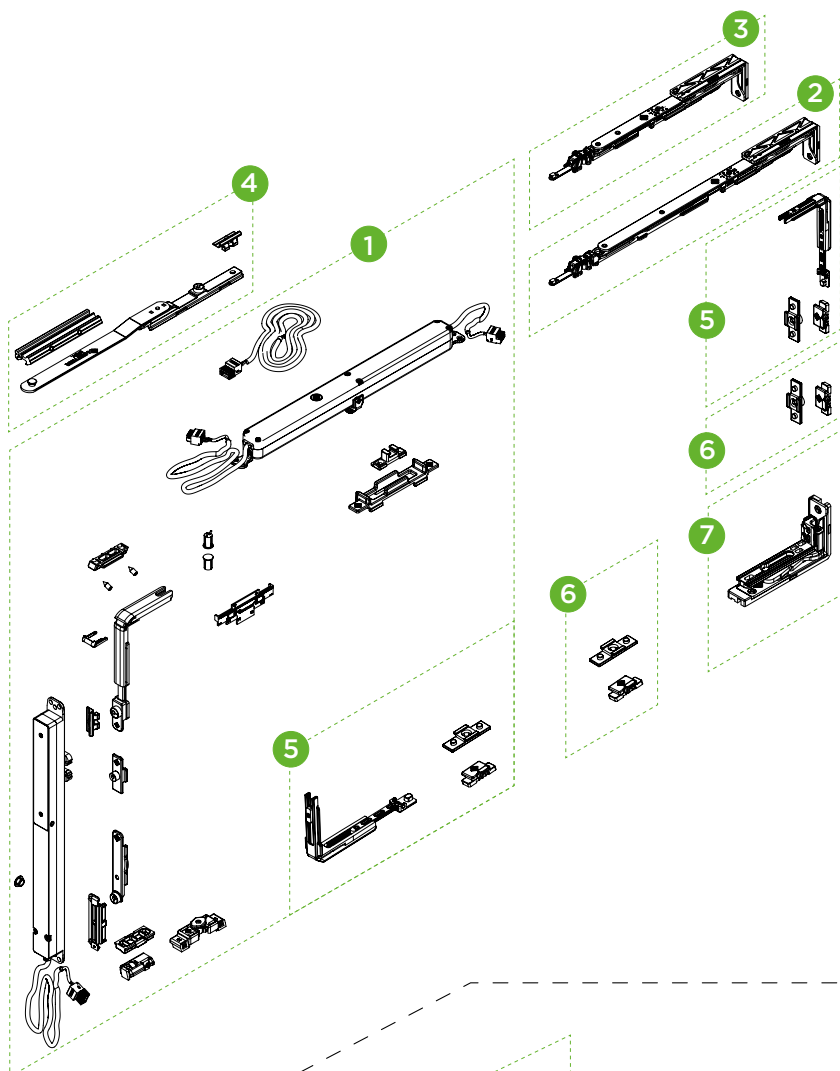

CONFIGURAZIONE ANTA RIBALTA TILT & TURN CONFIGURATION

	DESCRIZIONE DESCRIPTION	ART.
1	Kit base standard <i>Standard basic kit</i>	3326LG.1
2	Braccio lungo (per ante da 561 mm a 1700 mm) <i>Long arm (for sashes of 561 mm up to 1700 mm)</i>	3313L.20 S/D
3	Braccio corto (per ante da 430 mm a 560 mm) <i>Medium arm (for sashes of 430 mm up to 560 mm)</i>	3313L.21 S/D
4	Braccio supplementare (per ante da 1000 mm a 1700 mm) <i>Supplementary arm (for sash of 1000mm up to 1700mm)</i>	3521L.30
5	Chiusura supplementare laterale con riscontro regolabile (per braccio medio e lungo, per altezza anta superiore a 1200 mm) <i>Side supplementary closing with adjustable counterplate (for medium and long arm, for sash height more than 1200 mm)</i>	3400F.31
6	Punto di chiusura supplementare con riscontro regolabile <i>Supplementary locking point with adjustable counterplate</i>	3421.32
7	Cerniera a scomparsa inferiore regolabile per battente <i>Adjustable lower concealed hinge</i>	3313 S/D

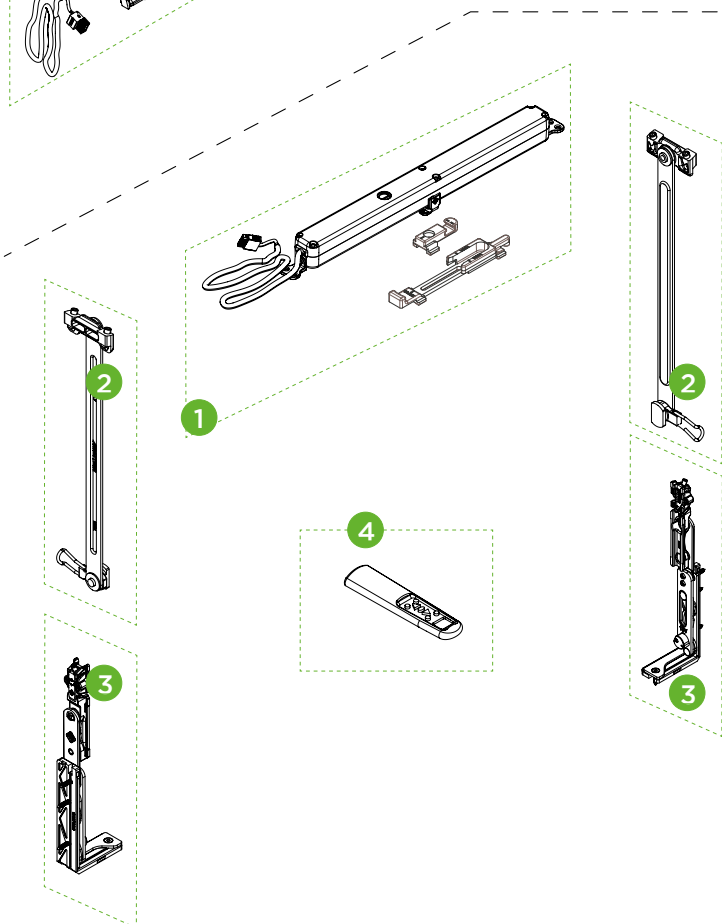

CONFIGURAZIONE VASISTAS BOTTOM HUNG CONFIGURATION

	DESCRIZIONE DESCRIPTION	ART.
1	WiCloud RC - Attutatore radiocomandato <i>WiCloud RC - Chain actuator with remote control</i>	1121.5
2	Simple plus - Braccio limitatore <i>Simple plus - Limiter arms</i>	1114.1
3	Cerniere a scomparsa regolabili per apertura a vasistas <i>Concealed adjustable hinge for transom opening</i>	3313.70
4	WiControl - Radiocomando (venduto separatamente) <i>WiControl - Remote Control</i>	1121.50

WICLOUD AR

KIT BASE ANTA RIBALTA AUTOMATICA



1D



2.5

3



Kit base anta a ribalta automatica | Base kit for automatic tilt and turn
 Kit pour vantail oscillo-battant motorisée | Kit oscilo batiente motorizado



Kit che permette di movimentare un infisso in apertura e chiusura a ribalta e battente ottenendo una chiusura perimetrale con N punti di chiusura. Rinvio d'angolo, terminali e riscontri in zama. Portata massima 130kg - 170kg in abbinamento a 3301.50



Kit for the opening and closing of a T&T window, with a perimeter closing at N points. Corner return, terminals and handles in zamak. Maximum load: 130 Kg - 170 Kg together 3301.50



Kit pour l'ouverture et la fermeture d'un châssis O/B, avec une fermeture sur périmètre à N points de fermeture. Renvoi d'angle, embout de tringle et gâches en zamak. Portée: 130 Kg - 170 Kg avec 3301.50



Kit para la apertura oscilo y batiente de la ventana con cierre perimetral y N puntos de cierre. Reenvío de ángulo bloqueo y cerradero de zamak. Soporta hasta: 130 kg - 170 Kg con 3301.50



ART.	3326LG.1			
Imballo Package Conditionnement Embalaje	1 Kit			
Finiture disponibili Available finishes Finitions disponibles Acabados disponibles	1	2	3	4

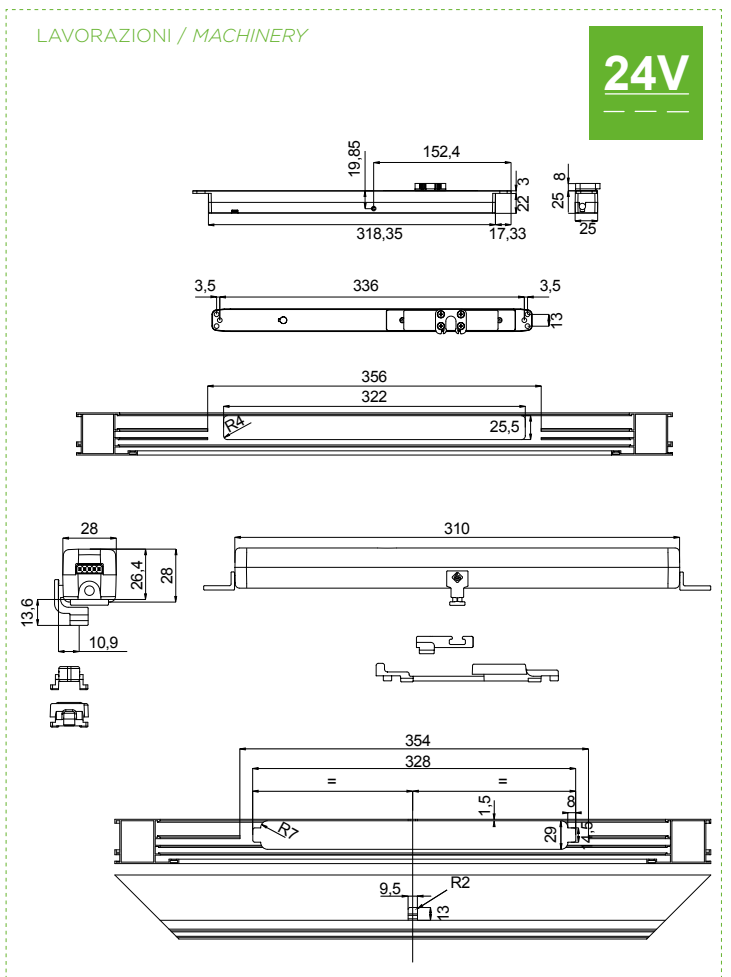
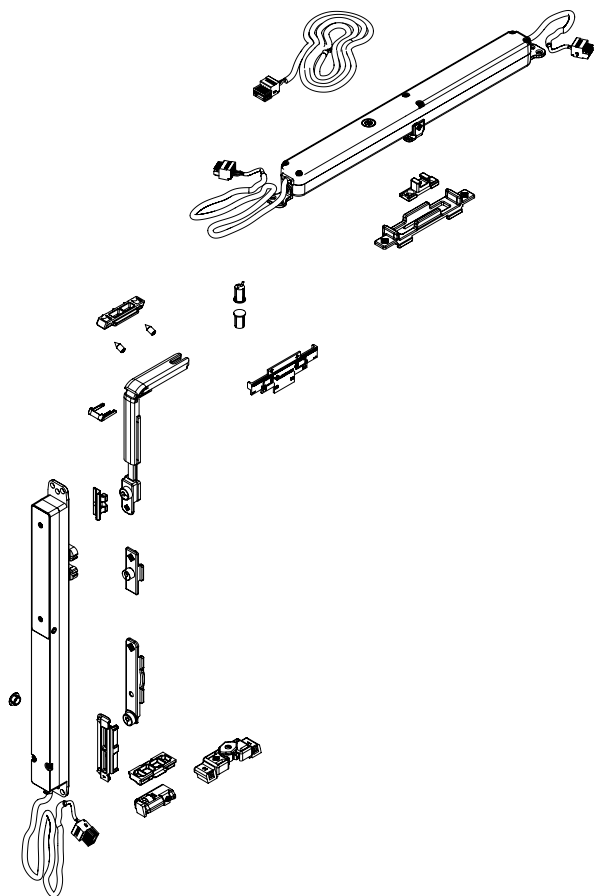
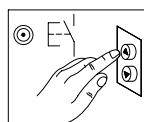
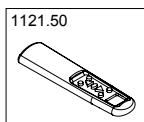



WICLOUD

ATTUATORE PER APERTURA VASISTAS



Attuatore per apertura vasistas | Chain Actuator for transom opening | Actionneur a chaine pour vasistas | Actuador para basculante

 Attuatore a catena per apertura motorizzata a vasistas in versione a controllo remoto.

 Chain actuator for motorized transom opening, in the version with remote control.

 Actionneur a chaine pour ouverture motorisée à vasistas dans la version contrôle à distance.

 Actuador para la apertura motorizada abatible, en versión con mando a distancia.

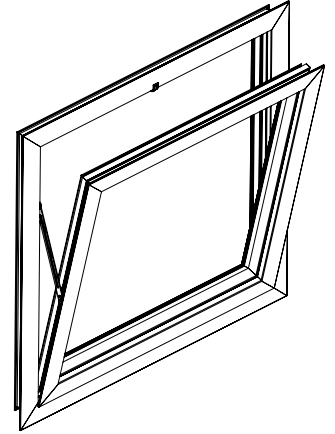

ART.	1121.5 1121.50 1121.9 1121A.6						
Imballo Package Conditionnement Embalaje	1 Kit						
Finiture disponibili Available finishes Finitions disponibles Acabados disponibles	<table border="1"> <tr> <td>1</td> <td>2</td> <td>3</td> <td>4</td> <td>5</td> <td>6</td> </tr> </table>	1	2	3	4	5	6
1	2	3	4	5	6		

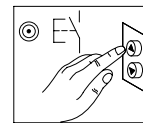
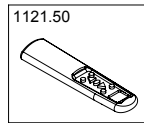

WICLOUD

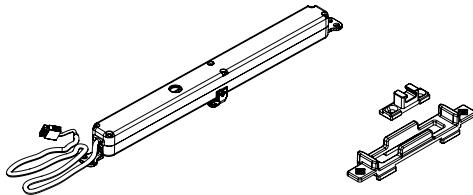

1121A.6

WICLOUD RC

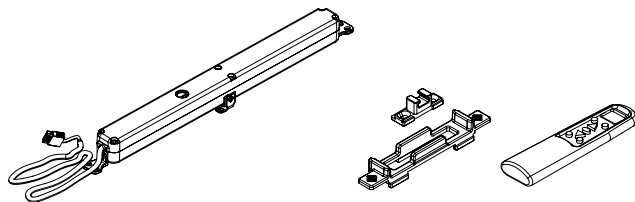

1121.5

1121.50

WICLOUD RC-LOCK

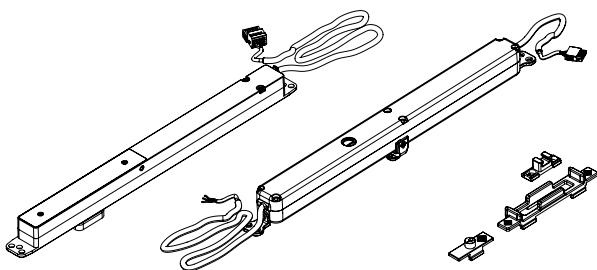

1121.9

LAVORAZIONI WICLOUD WICLOUD MACHINERY

24V

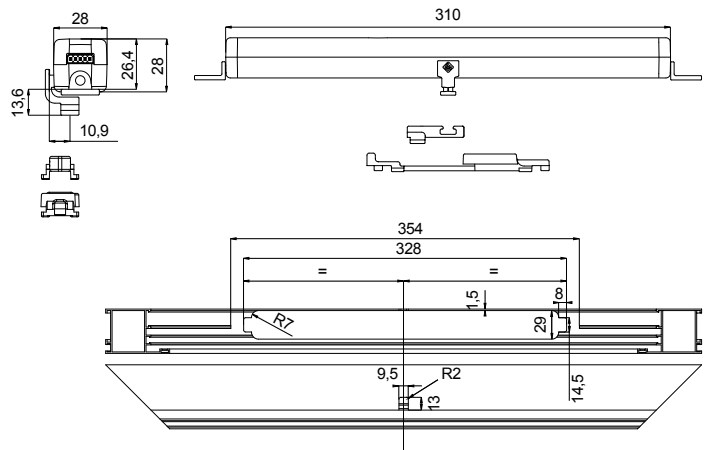

LAVORAZIONI WI LOCK / WILOCK MACHINERY

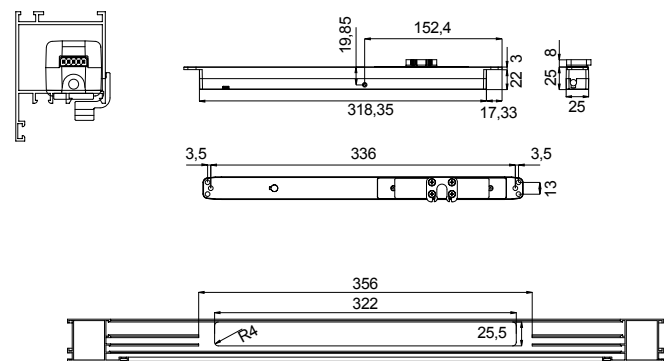

	WiCloud	WiCloud RC	WiCloud	WiLock
Descrizione <i>Description</i>	Attuatore a catena per apertura motorizzata a vasistas con comando a pulsante. <i>Chain actuator for motorized transom opening with button control.</i>	Kit composto dall'attuatore a catena in abbinamento alla serratura elettromeccanica per la movimentazione dei punti di chiusura; blocchetto in zama; eccentrico in acciaio inox. <i>Kit with chain actuator combined with Electromechanical lock to move locking points; zamak block, stainless steel eccentric.</i>	Kit che permette di movimentare un infisso in apertura e chiusura a ribalta e battente ottenendo una chiusura perimetrale con N punti di chiusura. <i>Kit for the opening and closing of a T&T window, with a perimeter closing at N points.</i>	
Codice Code	1121A.6	1121.5	1121.9 -3326LG.1	
Forza di spinta e trazione <i>Pressure and traction force</i>	200 N			600N
Corse (selezionabili in qualsiasi momento) <i>Track runs (can be selected at any time)</i>	70, 125, 170, 210mm			18mm / 36mm (± 1mm)
Tensione d'alimentazione <i>Voltage</i>	24 V			24V (20,4÷30V)
Assorbimento di corrente a carico nominale <i>Current consumption at nominal charge</i>	0,32A			1,4 A
Potenza assorbita a carico nominale <i>Charge absorbed at nominal load</i>	7,5W			32 W
Velocità di traslazione a vuoto <i>No load speed</i>	8mm/s			8 mm/s
Durata della corsa a vuoto <i>No load duration</i>	27 s			2,25 s (18mm) - 4,5 s (36mm)
Tipo di servizio <i>Type of service</i>	S2 di 3 min			S2 di 3 min
Temperatura di funzionamento <i>Operating temperature</i>	- 5 + 65 °C			- 5 + 65 °C
Grado di protezione dispositivi elettrici <i>Degree of protection for electrical devices</i>	IP32			IP 43
Funzionamento sincronizzato <i>Synchronized operation</i>				NON previsto <i>NOT provided for</i>
Forza di tenuta statica <i>Static seal strength</i>	1000N			850N
Finecorsa in apertura <i>Limit switch stop at opening</i>	Elettronico programmabile a dip-switch <i>Electronic, set by dip-switches</i>			Fisso, elettronico <i>Fixed, electronic</i>
Finecorsa in chiusura <i>Limit switch stop at closure</i>	Ad assorbimento di potenza <i>By power absorption</i>			
Lunghezza cavo di alimentazione <i>Power supply cable length</i>	2m			2m
Peso <i>Weight</i>	0,660Kg			0,650Kg

Articoli Complementari

Complementary Articles

05

1

Art. 3321G.1

Kit base standard con antifalsamanovra sulla cremonese

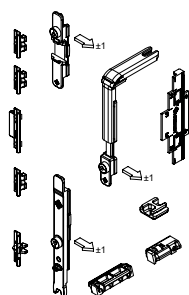

2

Art. 3321G.2

Kit base standard con antifalsamanovra superiore

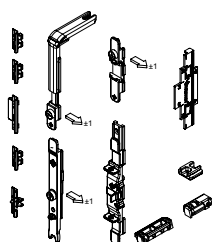

3

Art. 3321LG.1

Kit base manovra logica con antifalsamanovra sulla cremonese

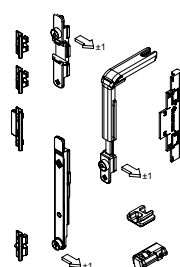

4

Art. 3321LG.2

Kit base manovra logica con antifalsamanovra superiore

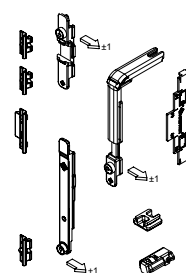





1

2

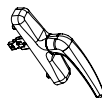
3

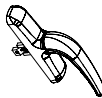
4

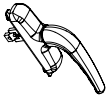
DESCRIZIONE DESCRIPTION	ART	ART KIT 3321G.1	ART KIT 3321G.2	ART KIT 3321LG.1	ART KIT 3321LG.2
CREMONESI CREMONE-BOLT					
"TWIST" Cremonese "TWIST" Cremonese bolt	 6011	X			
"COMFORT" Cremonese con manico asportabile "COMFORT" Cremonese bolt with removable handle	 6011.4	X			
"COMFORT" Cremonese "COMFORT" Cremonese bolt	 6011.10	X			

DESCRIZIONE DESCRIPTION		ART	ART KIT 3321G.1	ART KIT 3321G.2	ART KIT 3321LG.1	ART KIT 3321LG.2
"COMFORT" Cremonese con chiave "COMFORT" Cremonese bolt with key		6032.10	X			
"COMFORT 104" Cremonese "COMFORT 104" Cremonese bolt		6015	X			
"COMFORT 104" Cremonese int. 98mm "COMFORT 104" Cremonese bolt int. 98mm		6015.3	X			
"COMFORT 104" Cremonese con chiave "COMFORT 104" Cremonese bolt with key		6036	X			
"COMFORT 104" Cremonese con chiave int. 98mm "COMFORT 104" Cremonese bolt with key int. 98mm		6036.3	X			
"ITALIA" Cremonese "ITALIA" Cremonese bolt		6018	X			
"TWIST" Cremonese "TWIST" Cremonese bolt		6010.20		X		
"COMFORT" Cremonese con manico asportabile "COMFORT" Cremonese bolt with removable handle		6010.24		X		
"COMFORT" Cremonese "COMFORT" Cremonese bolt		6010.21		X		
"COMFORT" Cremonese con chiave "COMFORT" Cremonese bolt with key		6031.21		X		
"COMFORT 104" Cremonese "COMFORT 104" Cremonese bolt		6015.21		X		
"ITALIA" Cremonese "ITALIA" Cremonese bolt		6018.21		X		
"COMFORT LOGICA" Cremonese con chiave, per anta ribalta logica - DX "COMFORT LOGICA" Cremonese bolt with key, for Tilt before Turn - RX		6036.20D			X	
"COMFORT LOGICA" Cremonese con chiave, per anta ribalta logica - SX "COMFORT LOGICA" Cremonese bolt with key, for Tilt before Turn - LX		6036.20S			X	
"COMFORT LOGICA" Cremonese con chiave, per anta ribalta logica - DX "COMFORT LOGICA" Cremonese bolt with key, for Tilt before Turn - RX		6036.25D				X
"COMFORT LOGICA" Cremonese con chiave, per anta ribalta logica - SX "COMFORT LOGICA" Cremonese bolt with key, for Tilt before Turn - LX		6036.25S				X

DESCRIZIONE DESCRIPTION		ART	ART KIT 3321G.1	ART KIT 3321G.2	ART KIT 3321LG.1	ART KIT 3321LG.2
BRACCI ARMS						
"WEEN" Cerniera a scomparsa inferiore regolabile per A/R "WEEN" Adjustable Lower Concealed Hinge for T&T		3313 S/D	X	X	X	X
"WEEN" Cerniera a scomparsa con braccio regolabile per A/R "WEEN" Concealed Hinge with adjustable arm for T&T		3313.20 S/D	X	X		
"WEEN" Cerniera a scomparsa con braccio regolabile per A/R logica "WEEN" Concealed Hinge with adjustable arm for logic T&T		3313L.2 S/D			X	X
"WEEN" Cerniera a scomparsa inferiore regolabile per A/R "WEEN" Adjustable Lower Concealed Hinge for T&T		3313.21 S/D	X	X		
"WEEN" Cerniera a scomparsa inferiore regolabile per A/R "WEEN" Adjustable Lower Concealed Hinge for T&T		3313L.21			X	X
"2.0 DUEPUNTOZERO" Braccio supplementare per anta ribalta - L anta da 1200mm a 1700mm "2.0 DUEPUNTOZERO" Additional arm for tilt and turn - L sash from 1200mm to 1700mm		3521.30	X	X		
"2.0 DUEPUNTOZERO" Braccio supplementare per anta ribalta manovra logica - L anta da 1200mm a 1700mm "2.0 DUEPUNTOZERO" Additional arm for tilt before turn - L sash from 1200mm to 1700mm		3521L.30			X	X
CHIUSURE SUPPLEMENTARI SUPPLEMENTARY CLOSING						
"WEEN" Chiusura supplementare laterale con riscontro regolabile - H anta > 1400mm L anta > 1200mm "WEEN" Additional side closing with adjustable counterplate - H sash > 1400mm L sash > 1200mm		3421.31	X	X	X	X
"WEEN" Punto di chiusura supplementare "WEEN" Additional locking point		3421.32	X	X	X	X
"WEEN" Chiusura orizzontale inferiore - L anta > 1200mm "WEEN" Horizontal lower closing - L sash > 1200mm		3421.35	X	X	X	X
"WEEN" Microventilazione regolabile (non utilizzabile con 3400.20 e 3400L.20) "WEEN" Adjustable microventilation (not suitable with 3400.20 and 3400L.20)		3421.39	X	X	X	X
ASTINA ROD						
Astina in poliammide Polyamide rod		2010.1	X	X	X	X

DESCRIZIONE DESCRIPTION		ART	ART KIT 3321G.1	ART KIT 3321G.2	ART KIT 3321LG.1	ART KIT 3321LG.2
MARTELLINE E MOVIMENTAZIONE MONODIREZIONALE HANDLES AND ONE WAY MOVEMENT						
"SHARK MINIMAL" Movimentazione monodirezionale con anti falsa manovra - Entrata 3,3 mm "SHARK MINIMAL" One-way movement with anti-false manoeuvre - Backset 3,3 mm		3631	X		X	
"SHARK MINIMAL" Movimentazione monodirezionale senza anti falsa manovra - Entrata 3,3 mm "SHARK MINIMAL" One-way movement without anti-false manoeuvre - Backset 3,3 mm		3631.10		X		X
"SHARK MINIMAL" Movimentazione monodirezionale con anti falsa manovra - Entrata 3,3 mm "SHARK MINIMAL" One-way movement with anti-false manoeuvre - Backset 3,3 mm		3631.20	X		X	
"SHARK MINIMAL" Movimentazione monodirezionale senza anti falsa manovra - Entrata 3,3 mm "SHARK MINIMAL" One-way movement without anti-false manoeuvre - Backset 3,3 mm		3631.30		X		X
"SHARK" Movimentazione monodirezionale con anti falsa manovra "SHARK" One-way movement with anti-false manoeuvre		3628	X		X	
"SHARK" Movimentazione monodirezionale senza anti falsa manovra "SHARK" One-way movement without anti-false manoeuvre		3628.10		X		X
"ITALIA" Martellina Minimal Design "ITALIA" Minimal Design Handle		3090	X	X		
"ITALIA" Martellina minimal Int. 43mm "ITALIA" Minimal design handle Int. 43mm		3090.30	X	X		
"COMFORT" Martellina "COMFORT" Handle		3070	X	X		
"COMFORT" Martellina con chiave "COMFORT" Handle with key		3070.2	X	X		
"ITALIA" Martellina "ITALIA" Handle		3072.1	X	X		
"ITALIA" Martellina "ITALIA" Handle		3072	X	X		
"COMFORT LOGICA" Martellina DX "COMFORT LOGICA" RX handle		3070.25D			X	X
"COMFORT LOGICA" Martellina SX "COMFORT LOGICA" LX handle		3070.25S			X	X
ARTICOLI PER ANTA AFFIANCATA ARTICLES FOR INACTIVE SASH						
Cerniera a scomparsa inferiore regolabile per A/R Adjustable Lower Concealed Hinge for T&T		3313 S/D	X	X	X	X
Cerniera a scomparsa superiore regolabile per battente Upper concealed hinge for T&T		3313.71 S/D	X	X	X	X

<p>"BI-HID" Catenaccio a leva bidirezionale per anta affiancata <i>"BI-HID" Two-way latch for inactive sash</i></p>		4516.1	X	X	X	X
<p>Terminale superiore ed inferiore <i>Upper and lower rod end</i></p>		4516.50	X	X	X	X
<p>Rostro di chiusura supplementare regolabile <i>Additional intermediate third closing point adjustable</i></p>		4226.1	X	X	X	X
<p>Incontro asta doppio regolabile <i>Double adjustable striker</i></p>		4205.5	X	X	X	X
BRACCIO LIMITATORE LIMITER ARM						
<p>"SIMPLE PLUS" Braccio limitatore per finestre <i>"SIMPLE PLUS" Limiter arm for windows</i></p>		1114.1	X	X	X	X

Configurazioni Vasistas

Bottom hung Configuration

2000

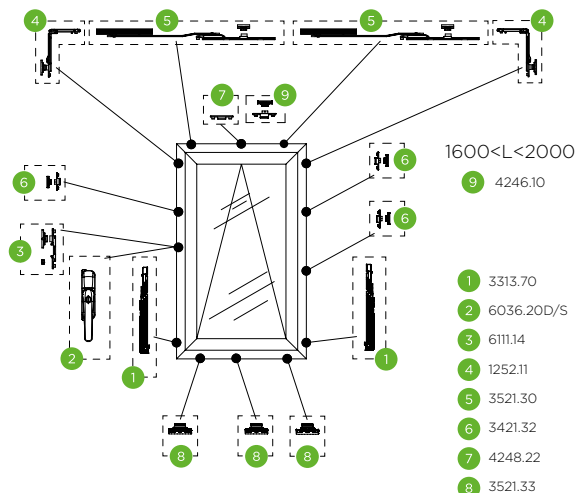
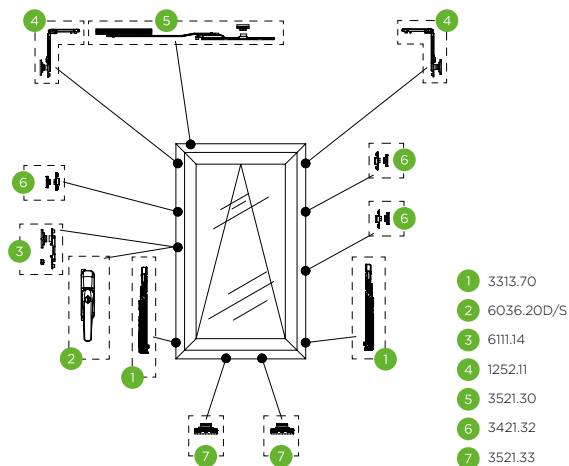

1600

1100

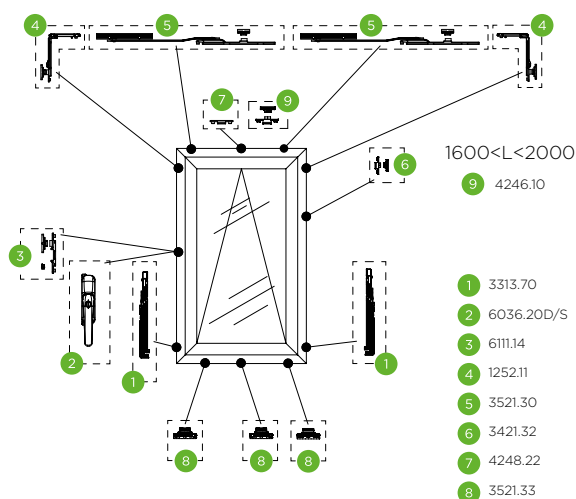
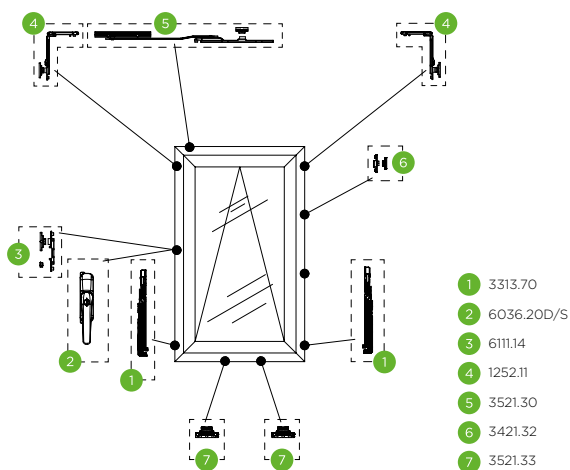

H > 800mm

510

520

1100

2000

Configurazioni Anta Ribalta Standard

Standard Tilt and Turn Configuration

Portate > 110 kg Art. 3310.50 Obbligatorio | Weight > 110 kg Art. 3310.50 Obligatory

2700

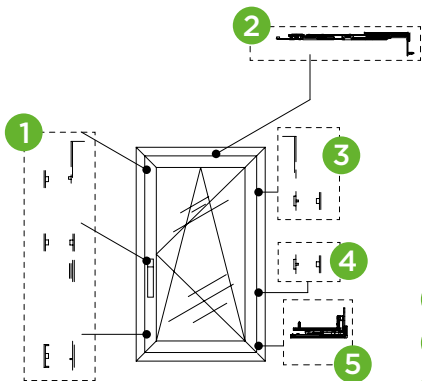

5+3 punti di chiusura
5+3 closure points

- 1 KIT BASE
- + 3313.20 S/D
- + 3421.31
- + 3421.32
- + 3313 S/D

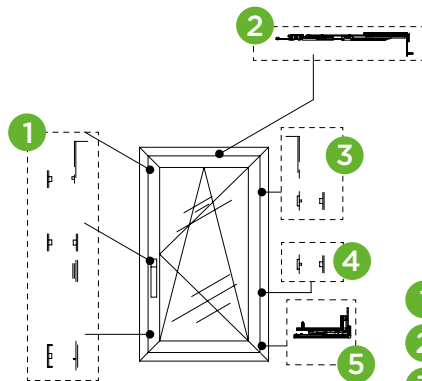

5+3 punti di chiusura
5+3 closure points

- 1 KIT BASE
- + 3313.21 S/D
- + 3421.31
- + 3421.32
- + 3313 S/D

2200

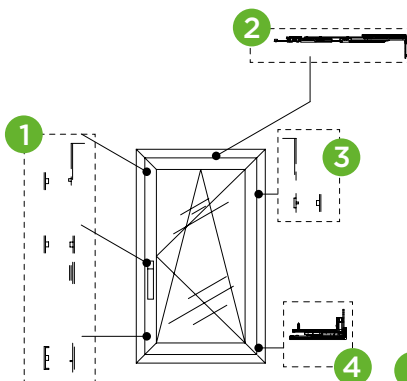

5+2 punti di chiusura
5+2 closure points

- 1 KIT BASE
- + 3313.20 S/D
- + 3421.31
- + 3313 S/D

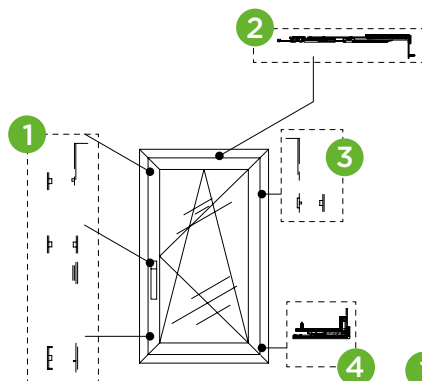

5+2 punti di chiusura
5+2 closure points

- 1 KIT BASE
- + 3313.21 S/D
- + 3421.31
- + 3313 S/D

1400

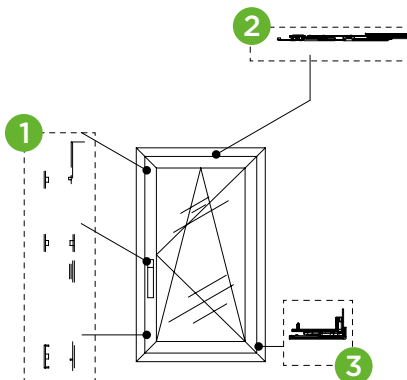

5 punti di chiusura
5 closure points

- 1 KIT BASE
- + 3313.20 S/D
- + 3313 S/D

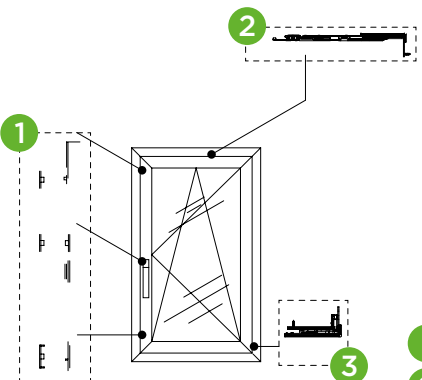

5 punti di chiusura
5 closure points

- 1 KIT BASE
- + 3313.21 S/D
- + 3313 S/D

550

440

570

800

1200

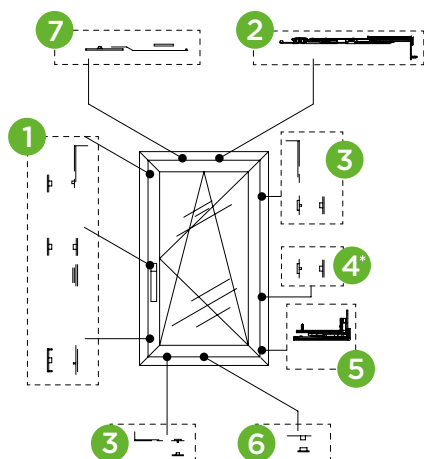

- 1 KIT BASE
 - + 3313.21 S/D
 - 2 3421.31 x2
 - + 3421.32
 - 3 3313 S/D
 - + 3421.35
 - 4 3521.30
- 5+6 punti di chiusura
5+6 closure points

4* obbligatorio
obligatory H>2200

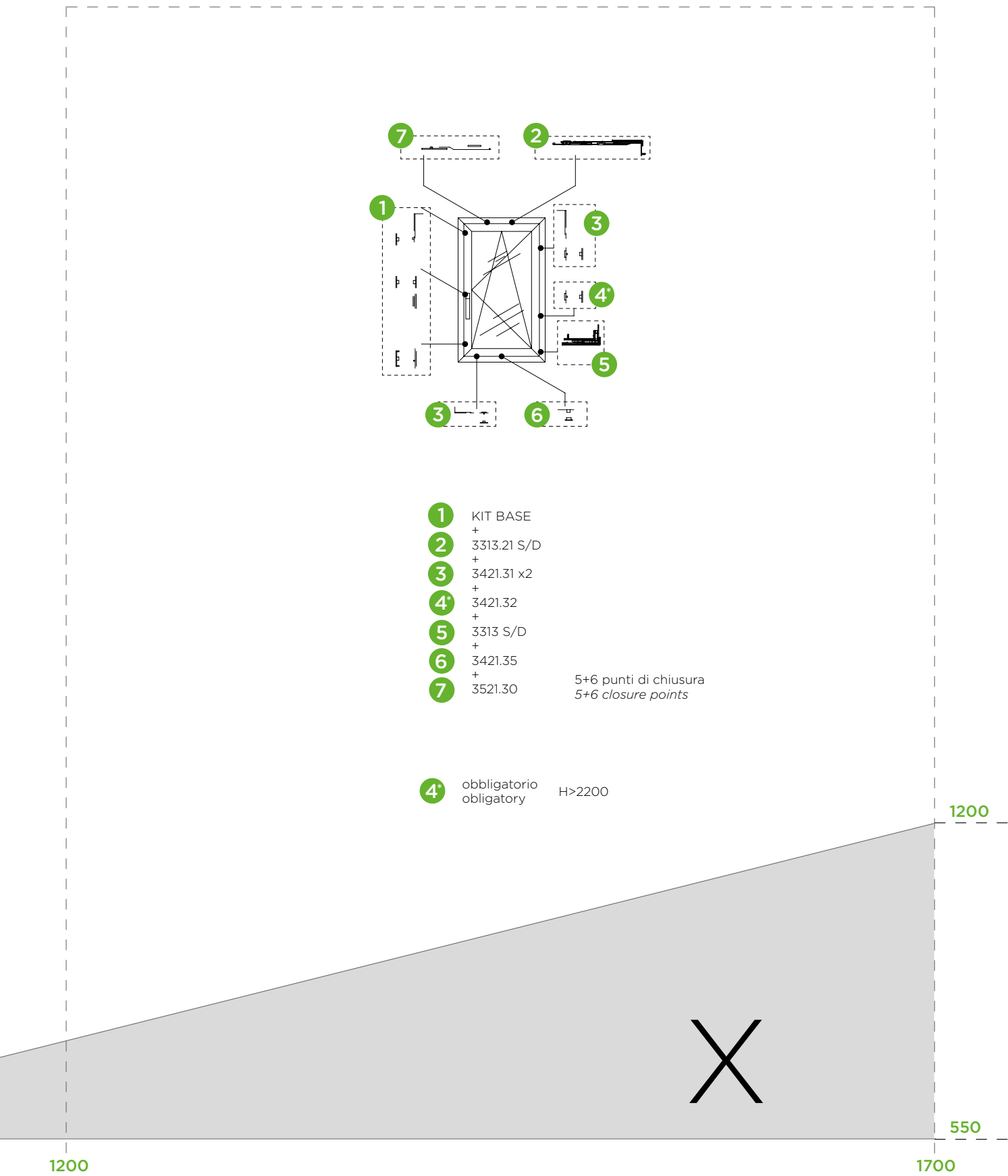

1200

1700

1200

550

Configurazioni Manovra Logica

Tilt-Before-Turn Configuration

Portate > 110 kg Art. 3310.50 Obbligatorio | Weight > 110 kg Art. 3310.50 Obligatory

2700

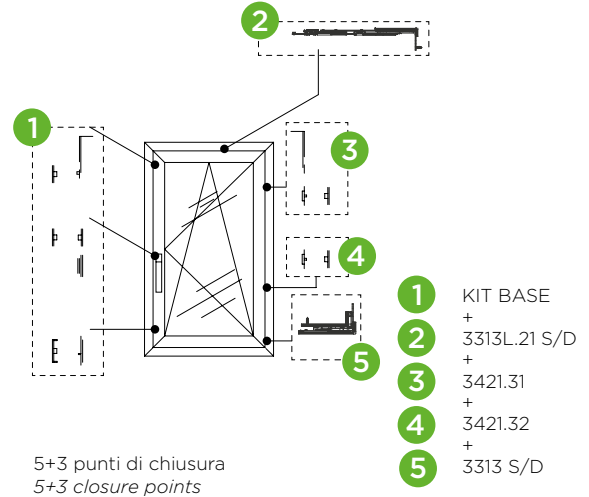
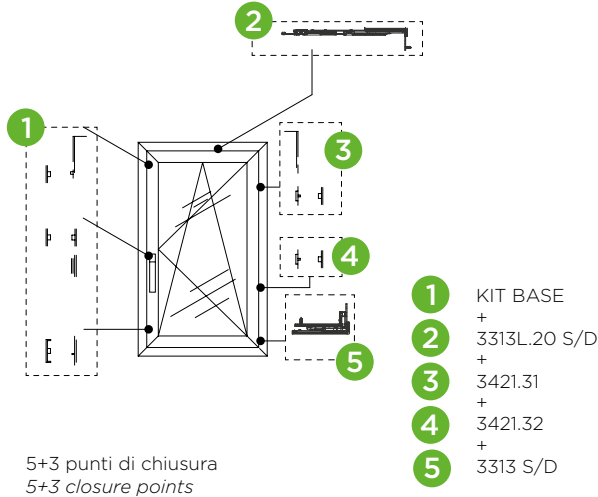

2200

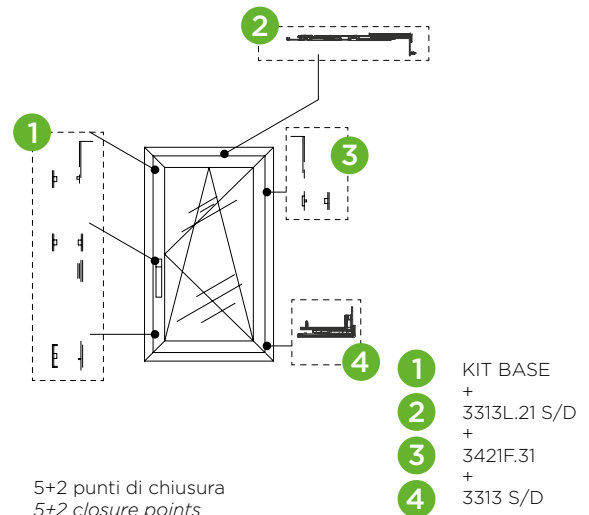
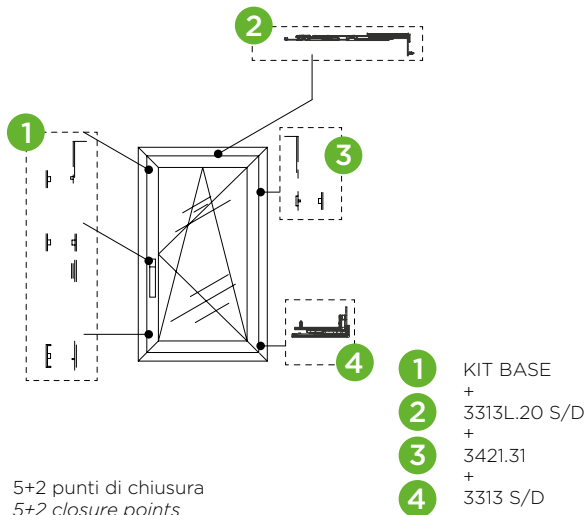

1400

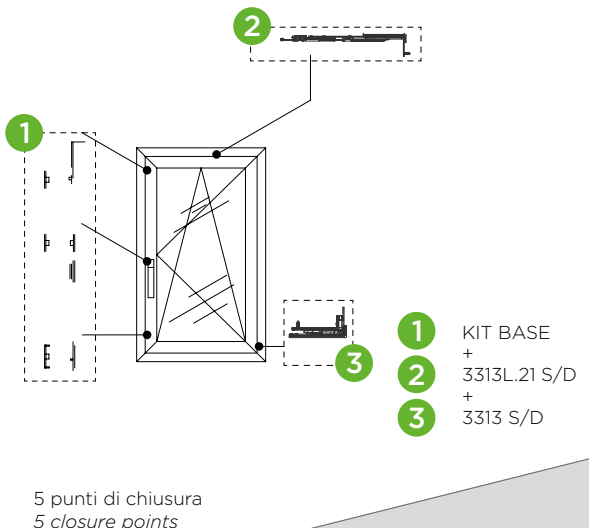
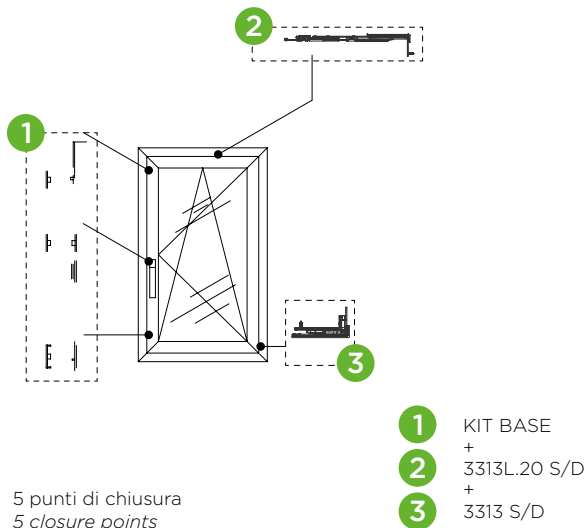

550

440

570

800

1200

KIT BASE = 3321LG.1 - 3321LG.2

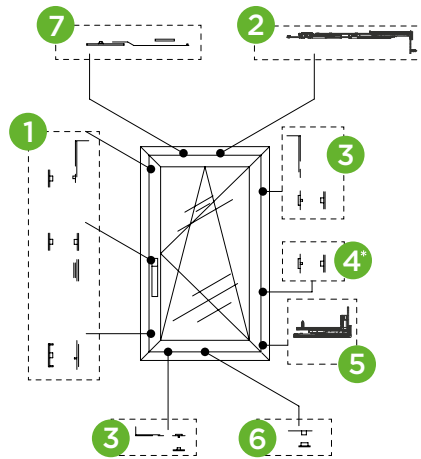

- 1 KIT BASE
- + 3313L.21S/D
- 2 3421.31 x2
- + 3421F.32
- 3 3313 S/D
- + 3421.35
- 4 3521L.30
- 5+6 punti di chiusura
- 5+6 closure points

4* obbligatorio
obligatory H>2200

1200

550

1200

1700



Configurazioni Battente

Casement Configuration

07

Portate > 110 kg Art. 3310.50 Obbligatorio | Weight > 110 kg Art. 3310 .50 Obligatory

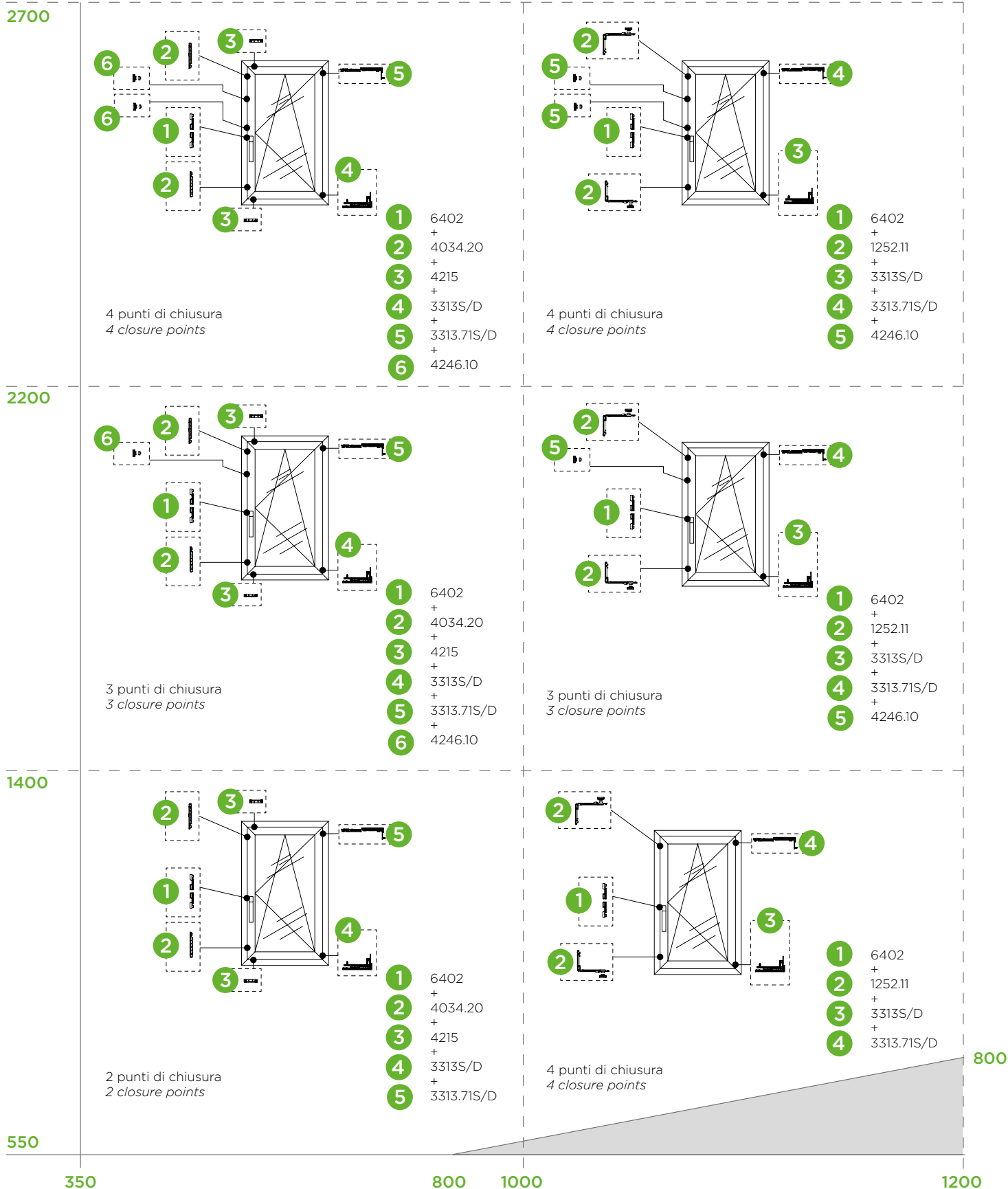





Master Italy S.r.l

S.P. 37 Conversano - Castiglione km 0.570 - Conversano (Ba) Italy
Customer Service **+39 080.4959823** | Fax. **+39 080.4959030**
info@masteritaly.com

